

Color Digital Camera

Technical Manual



DFW-SX910/X710

Table of Contents

Overview

Main Features	3
System Components	5
Connection Diagram	6
Location of Parts and Operation	7

Functions

IIDC Standard Features	8
Brightness	8
Auto Exposure	8
Sharpness	8
White Balance	8
Hue	8
Saturation	8
Gamma	9
Shutter	9
Gain	10
Trigger Shutter	10
Pan/Tilt	11
Optical Filter	11
Memory Channels	11
Partial Scan	12
IIDC Extended Features	13
Memory Shot	13
PAINT	14
User Memory Area	14
Non-IIDC Features	14
1394 Bus Synchronization	14
Exposure Out	14

Control

Camera Command Status Register	15
Memory Map	15
ConfigROM	16
Control Base Address	18
Verifying Supported Video Modes	18
Video Mode Settings	20
Starting/Stopping Video Transfer (Continuous Shot) ..	20
One Shot and Multi Shot	20
Memory Channel Operation	21
Feature Controls (Complies with the IIDC Standard) ..	22
Feature Controls (IIDC Extended)	27
PAINT Control	28
Memory Shot Control	28
User Memory Control	28
Partial Scan Operations	29

Appendix

Notes on the Camera Operations	32
Timing Between External Trigger Signal and Video	
Signal Output	34
Specifications	35
CCD Pixel Location (Top View)	39
Spectral Sensitivity (Relative Response)	
Parameters	40
Dimensions	41

Overview

The DFW-SX910 with its $\frac{1}{2}$ -type PS IT CCD, and the DFW-X710 with its $\frac{1}{3}$ -type PS IT CCD are high-resolution industrial-use digital video camera modules. The IEEE1394–1995 digital interface realizes a transfer speed of 400 Mbps and outputs SXGA (1280 × 960)/YUV (4:2:2)/7.5 fps with the DFW-SX910, XGA (1024 × 768)/YUV (4:2:2)/15 fps with the DFW-X710. In addition, the DFW-SX910/X710 also adopts a primary color filter CCD to realize good color reproducibility, as well as a square pixel CCD to eliminate the need for aspect ratio conversion in the image processor.

What is the IEEE1394?

The IEEE1394 is the standard serial bus for sending and receiving digital data. It is prescribed as “IEEE* Std. 1394-1995 IEEE Standard for a High Performance Serial Bus.”

The most outstanding feature of this interface is that it realizes transfer speeds of up to 400 Mbps and can handle large image data size. The interface is also capable of “Isochronous transmission” which transmits data real-time, for up to 64 channels. Connectors can be inserted and disconnected while the unit is turned on, and no terminators and no ID settings such as those necessary for the SCSI interface are required.

* The Institute of Electrical and Electronics Engineers, Inc.

Main Features

The DFW-SX910 video camera module utilizes a $\frac{1}{2}$ -type PS IT CCD, and the DFW-X710 utilizes a $\frac{1}{3}$ -type PS IT CCD

High-speed digital interface IEEE1394

The transmission speed is 400 Mbps. The DFW-SX910 can output a digital image at 7.5 frames per second; the DFW-X710 can output a digital image at 15 frames per second.

High-resolution

The DFW-SX910 (SXGA) has a high-resolution CCD of 1.45 million pixels. The DFW-X710 (XGA) has a high-resolution CCD of 800,000 pixels. Because the CCDs are square pixel CCDs, you don't need to convert the aspect ratio in your image processing.

External trigger function

The external trigger shutter function allows the image exposure to be coordinated with external equipment and moving objects.

For exposure time, the unit is equipped with Trigger Mode 0, which indicates the length of the exposure using the shutter parameter, and Trigger Mode 1, which controls exposure time by the width of the trigger signal.

It is also able to utilize a software trigger initiated by a command from a program running on a host computer.

Partial scan output image format

You can select and output any rectangle part from a full-size image. This allows you to efficiently capture images at a faster frame rate.

C-mount

Non-compressed YUV4:1:1/ YUV4:2:2/ Mono8 (8 bits each)

Solid aluminum diecast chassis

System Components

The DFW-SX910/X710 Video Camera Module system comprises the following components.

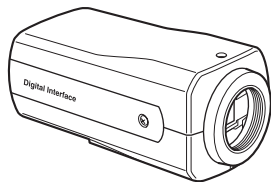

Video Camera Module
DFW-SX910/X710

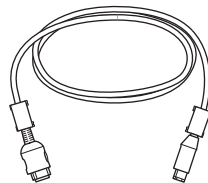

IEEE1394 Cable
(6-pin, 4.5 m)

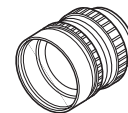

C-mount Lens
J6 x 11 MACRO (Canon)
25MM HD LENS VF2509 (Canon)

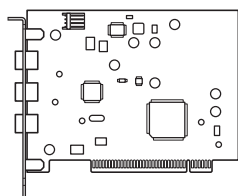

Host Adapter Card
(Commercially available)

Connection Diagram

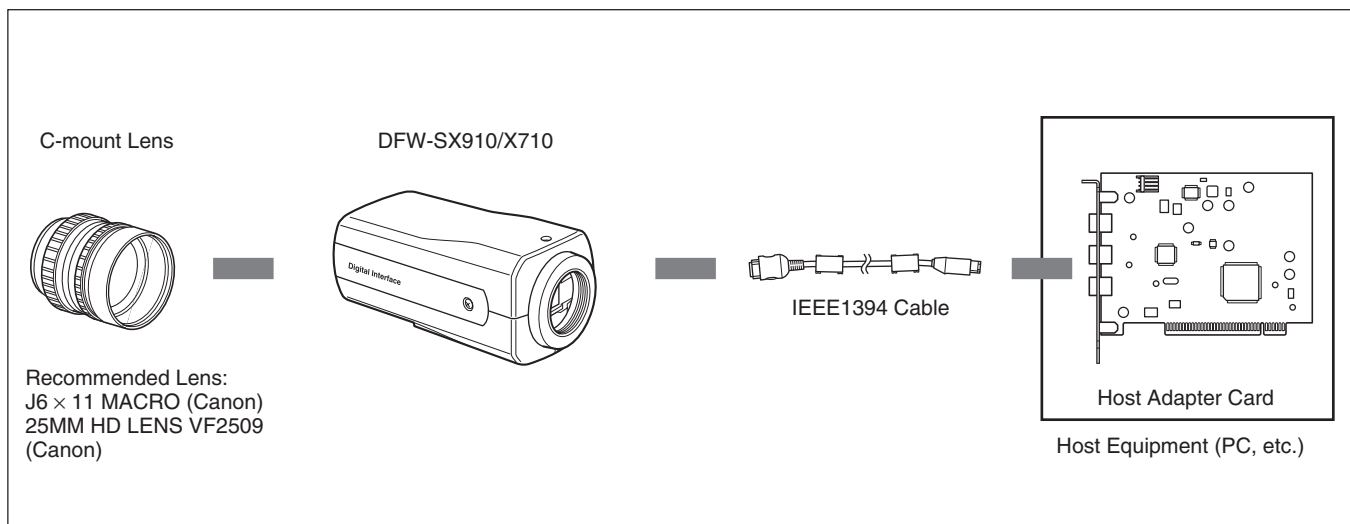

Location of Parts and Operation

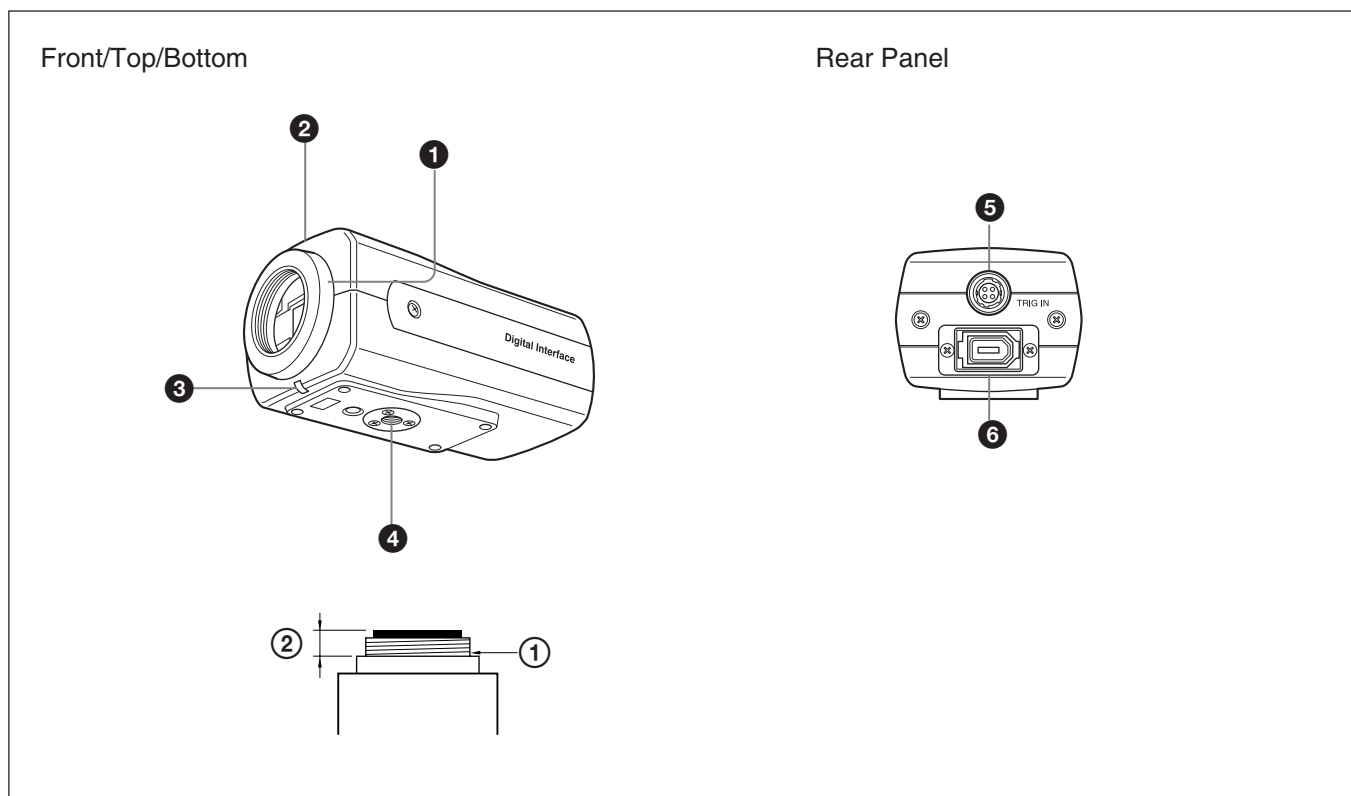

① Lens mount (C-mount)

Attach any C-mount lens or other optical equipment.

Note

The lens must not project more than 7 mm ($\frac{9}{32}$ inch) from the lens mount.

① Lens mount face ② 7 mm ($\frac{9}{32}$ inch) or less

② Flange back hole

Adjust the flange back by adjusting the screw at the bottom of this hole.

③ Pilot lamp

This lamp indicates the camera module operation states:

OFF: Camera power OFF

Green: Camera power ON/Video signal output OFF

Orange: Camera power ON/Video signal output ON

④ Tripod hole

Install a tripod into this hole.

⑤ TRIG IN/Exposure OUT connector

Connect the trigger signal generator (trigger output connector) to this connector.

When trigger is OFF, or software trigger is ON, a signal that indicates the exposure time is output from pin 1 of the camera.

For details on the exposure out, see “Exposure Out” (page 14).

⑥ CAMERA connector

Connect the IEEE1394 camera cable (supplied) to this connector.

Functions

IIDC Standard Features

Following features are defined by the IIDC standard, v1.30. Only the Trigger feature is defined by the IIDC standard, v1.31.

Brightness

This feature makes fine adjustment of the black level possible.

Auto Exposure

This feature automatically adjusts the gain and shutter settings, based on the brightness of the subject. To use this feature, set the camera features and the video format/mode as follows. This feature may not function properly in any other settings.

Standard settings

DFW-SX910 Video Format: 2
Video Mode: 0
Frame Rate: 7.5 fps
Trigger: OFF

DFW-X710 Video Format: 1
Video Mode: 3
Frame Rate: 15 fps
Trigger: OFF

Sharpness

The picture can be adjusted using eight levels of sharpness.

White Balance

This feature adjusts the color balance of the camera to ensure that a white subject appears white in the video image. Both manual and automatic settings are available.

There are two automatic white balance modes; Auto White Balance and One Push White Balance.

In the Auto White Balance mode, the camera senses any change in lighting and automatically adjusts White Balance accordingly. In the One Push White Balance mode, the White Balance is adjusted automatically once and fixed until you perform the adjustment again. The camera's internal circuits integrate the image data within a defined area, using an algorithm that approximates the average value to white. Because of this algorithm, depending on the lighting environment, a white subject may appear other than white in the Auto White Balance mode.

We recommend that you shoot a white subject so that white fills the entire screen in the specified lighting environment and then perform the One Push White Balance adjustment. When the calculation is completed, the White Balance in this lighting environment is adjusted.

The range of operation of each mode is as follows.

Manual : 2400 to 10000 K or more

Auto/One Push Auto: 2400 to 10000 K or more

Additionally, the camera employs a feature which can change the reference point of the White Balance. For details, see "PAINT" on page 14.

Hue

This feature adjusts color tones.

Saturation

This feature adjusts color intensity.

Gamma

Used for setting gamma compensation to OFF, ON (1), or ON (2).

OFF : Outputs CCD signals for image processing linearly.

ON (1) : For obtaining natural gradation taking into account the characteristics of the monitor.

ON (2) : For obtaining three-dimensional images with a subject that has a small luminance dynamic range.

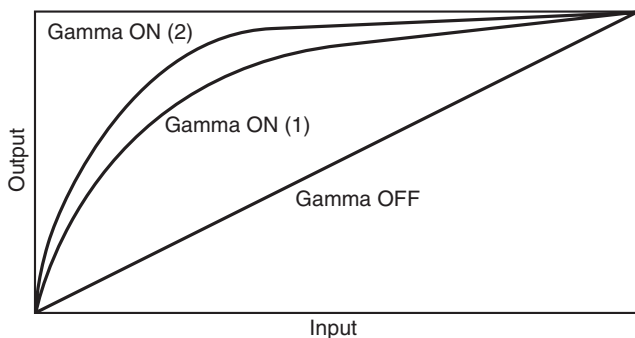

Concept of Gamma Characteristics

Setting examples

3 (003h) :	14 μs (1/100000)
32 (020h) :	1.005 ms (1/1000)
100 (064h) :	10.005 ms (1/100)
1000 (3E8h) :	1 s
1010 (3F2h) :	2 s
1150 (47Eh) :	16 s

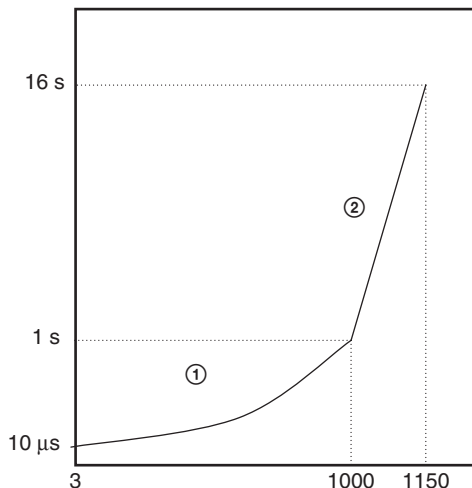

Shutter

This feature sets exposure time. Both manual and automatic settings are available.

When the automatic setting is selected, Shutter is adjusted automatically, based on the brightness of the subject.

At this time, the reference level (target point) of the brightness is set in the Auto Exposure register.

With manual setting, the camera uses relative control values indicated by a 12-bit integer and absolute control values indicated using a 32-bit floating point number.

Relative control values for Shutter

The relationship between the parameter and the exposure time is given by the following formulas.

Where

P = Parameter (003h ~ 47Eh)

E = Exposure time (s)

P >= 3 ~ P <= 1000

$$E = \frac{P^2}{1000000} + 0.000005 \text{ ————— ①}$$

P > 1000 ~ P <= 1150

$$E = (P - 1000) * 0.1 + 1.000005 \text{ ————— ②}$$

For details on Auto Exposure, see page 8.

For long exposure times

When exposure times longer than the currently set frame rate cycle are set, the camera enters the long exposure time mode, and the actual frame rate is slowed in accordance with the exposure time.

Absolute control values for Shutter

Control of exposure time using absolute values is possible. The values are indicated using a 32-bit floating point value. (Unit: sec.)

The control steps are synchronized with the pixel clock, and as the pixel clock is 15.25 MHz, one step is approximately 65.6 ns.

The range for these values extends from 10 microseconds to 17.5 seconds.

Programming example;

```
union {
    DWORD    dwValue;    // 1394 is expressed in quadlets,
    float    fValue;    // exposure time is indicated in seconds.
} AbsoluteShutterValue;

AbsoluteShutterValue.fValue = Exposure time;
WriteQuad(AbsoluteShutterOffsetAddress,
          AbsoluteShutterValue.dwValue);
```

WriteQuad is a virtual function used to write in the 1394 register.

AbsoluteShutterOffsetAddress is an offset address for the absolute value control. See page 26 for the formula for the offset address.

The change in shutter time will be used when the next exposure starts. The current exposure will complete with the previous shutter setting. This is true for all exposure; short or long. If you intend to reflect the new setting immediately, stop the output and start it again.

Gain

This feature adjusts the brightness of the picture. Both manual and automatic settings are available. The variable range extends from 0 to 18 dB.

When automatic setting is selected, Gain is adjusted automatically, based on the brightness of the subject. At this time, the reference level (target point) of the brightness is set in the Auto Exposure register. For details on Auto Exposure, see page 8.

70 to 511 Gain = $20\log_{10}([658+code]/[658-code]) - 0.35$
 512 to 551 Gain = $(0.0354)(code) - 0.35$

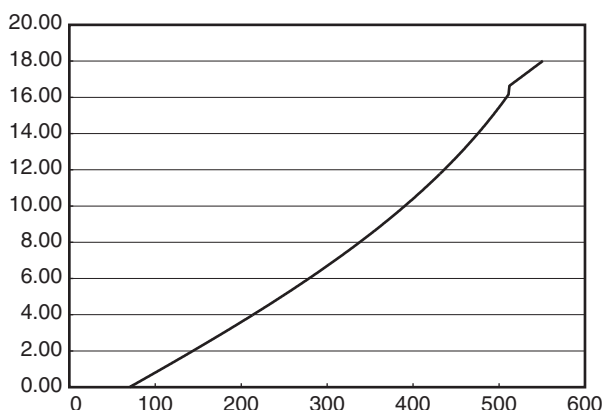

Trigger Shutter

This feature allows you to control the exposure timing via a external signal input (Hardware Trigger) or via a command sent from application software (Software Trigger). There are two trigger modes:

- Trigger Mode 0 where the exposure time is controlled by the shutter parameter
- Trigger Mode 1 where the exposure time is controlled by the trigger pulse width.

In both modes, the leading edge of the hardware trigger starts the exposure. In Trigger Mode 0, the maximum exposure is limited by the shutter parameter. In Trigger Mode 1, there is no limit to the exposure time.

Software Trigger is defined by IIDC Standard, v1.31.

Trigger Mode 0

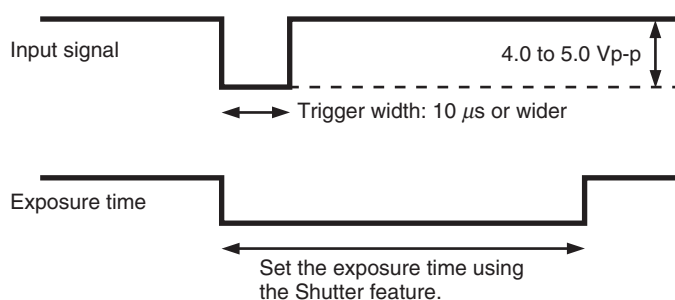

Trigger Mode 1

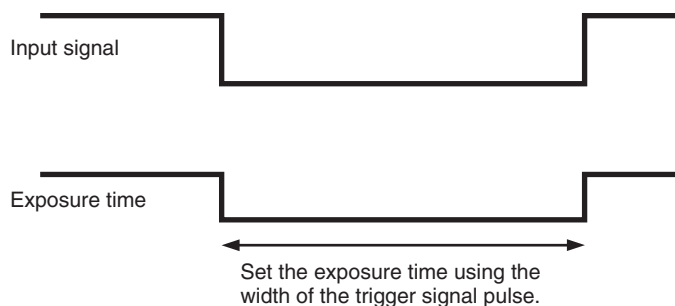

• Input impedance: 10 kΩ

It is possible to trigger the cameras at full frame rate using hardware trigger. (This was not possible with the earlier DFW-SX900/X700 because the trigger in would not be accepted until after the previous images was output from the camera.) It is very important that the exposure not end before the previous image is out of the cameras. If the camera is trigger too fast or there is noise on the trigger line that will cause the exposure to end before previous image is output, you will get double exposure of the image.

Pan/Tilt

Pan/Tilt is a feature to move a region of interest (ROI) image (smaller than the full image) vertically and horizontally about the full image of the camera. When the ROI image is defined (use the video mode setup), the ROI is centered in the full image.

Optical Filter

Normally, Optical Filter is the feature which switches electronic optical filters, such as an ND filter or a color conversion filter. However, on this camera, the feature chooses the preset values of White Balance. If 0 is set, White Balance for 3200 K is utilized. If 1 is set, White Balance for 5600 K is utilized.

This feature is effective when the color temperature of the shooting environment is 3200 K or 5600 K.

Memory Channels

The camera is equipped with two channels of nonvolatile memory to hold camera settings. The settings of all camera features and the video mode can be stored. The camera memorizes the channel most recently used to read out the setting information, and retains it, even if the power is turned off. Therefore, the camera loads the information from that channel when the power is turned on.

The video mode settings are loaded only when the power is turned on.

To start up the camera with the desired setting, perform the following procedure.

- 1** Make changes to the camera features or the video mode settings.
- 2** Store the current setting in Memory Channel 1 or Memory Channel 2.
- 3** Load the information that was stored in step **2**.

When you start up the camera the next time, the settings that you have just made will be loaded automatically.

Using the CameraInitialize command, the setting information stored in the channels is cleared and the camera features and the video mode are reset to their initial values. To preserve the information in the channels, be sure not to send the CameraInitialize command while driver software or application software is starting up.

The value saved for Pan/Tilt is initialized when the video mode is changed. To preserve the value, be sure not to change the video mode while driver software or application software is starting up, or before sending the video start command.

Partial Scan

The Partial Scan feature for outputting a small part of the full image called a Region of Interest (ROI). The ROI can be defined as any single contiguous rectangle that can be drawn on an even 16×16 grid of the whole image. The Unit Cell is the smallest region of interest that can be defined as is one of the rectangles on the even 16×16 grid.

DFW-SX910 unit cell = 80×60 pixels

DFW-X710 unit cell = 64×48 pixels

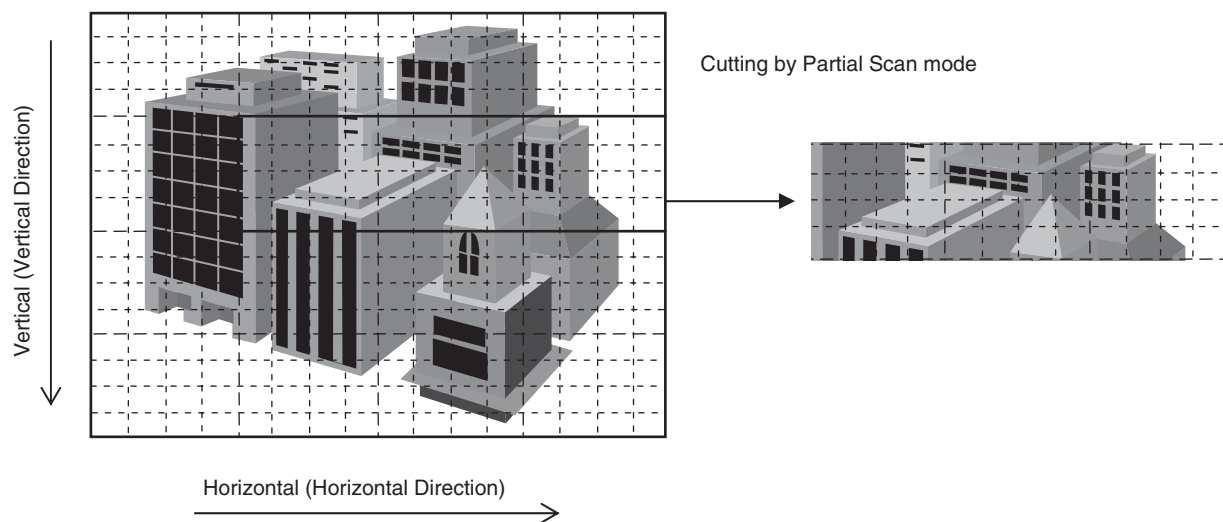

The frame rate of the camera can be increased by reducing the number of vertical lines output. In Partial Scan mode, the frame rate is determined by the exposure/shutter time plus the time to transmit the image. In free run mode, the exposure starts after the last image is transmitted. In triggered mode, the exposure can be overlapped with the image output but care must be taken to ensure that the exposure end does not occur before the output of the previous image.

To use the Partial Scan feature, set Format7, Mode0.

In Partial Scan mode, you can select from among Mono8, YUV4:1:1, and YUV4:2:2 as the color coding.

IIDC Extended Features

Following are vender-unique features, which are not defined by the IIDC standard.

Memory Shot

Memory Shot allows the camera to collect one or more images into on-board image memory without tying up available 1394 bus bandwidth. Normally, a 1394 IIDC camera transmits a new image immediately after the acquisition so the 1394 bus bandwidth is pre-allocated to the camera to ensure deterministic performance. 1394 bus bandwidth is allocated based on resolution and frame rate assigned. Multiple camera configurations frequently demand more bandwidth (or more ISO channels) than available on a single 1394 bus. The user can either reduce the bandwidth required by each cameras by reducing the frame rate or resolution or increase available bandwidth by adding more 1394 busses on one or more computers. Memory Shot offers another alternative to managing the 1394 bus bandwidth in multiple camera configurations. This

is especially useful in hardware triggered environments. Multiple cameras can be setup to acquire one or more images simultaneously without consuming any 1394 bus bandwidth. The applications software can setup the multiple cameras on a single 1394 bus on one computer for Memory Shot acquisition, query the camera to verify that the image(s) are in the camera on-board memory, and tell each camera to transmit its stored image(s). These cameras have 128 Mbit of frame memory.

- It can hold:
- 1280×960 at YUV4:2:2 is 6 images
 - 1280×960 at YUV4:1:1 is 9 images
 - 1280×960 at MONO8 is 13 images

The number of images (N) that can be held is defined by the image size and color coding.

$$N = 16 * 1024 * 1024 \text{ (byte)} / (W * H * K)$$

- W: image width (pixels)
- H: image height (pixels)
- K: coefficient of color coding

K	color coding
1	Mono8/Raw8
1.5	YUV4:1:1
2	YUV4:2:2

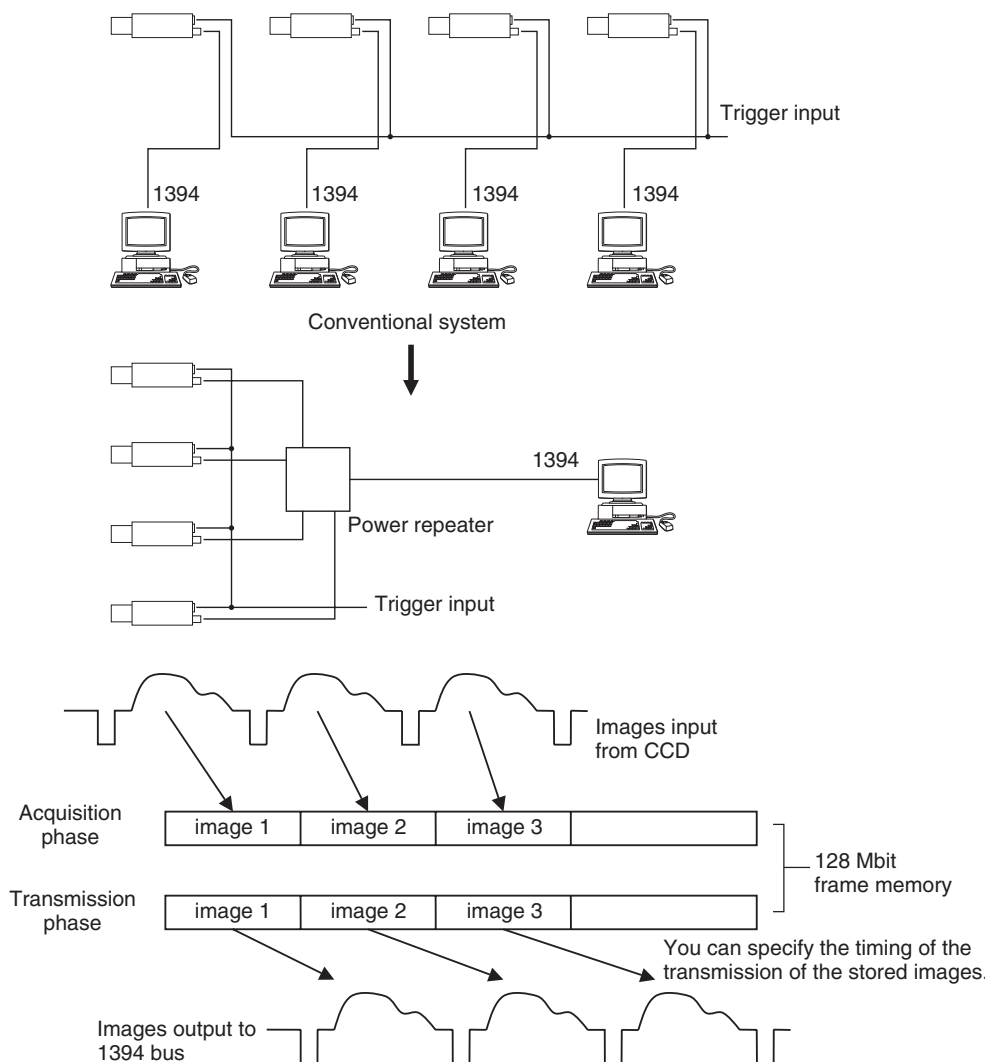

PAINT

This feature enables you to shift the reference point of the White Balance. If you change the parameter of this feature, the white-balance adjustment references to a color other than white.

User Memory Area

The camera is equipped with 256 bytes of nonvolatile memory to hold information you need.

The information is read or written by quadlet. Both Quadlet Read/Write and Block Read/Write transactions are available. The information will be preserved even if the power to the camera is turned off.

Non-IIDC Features

The following features are not defined by the IIDC standard.

1394 Bus Synchronization

Cameras connected to the same bus are automatically synchronized. Specifically, the start of exposure will be the same for all cameras running at the same frame rate.

The DFW-SX910/X710 series and XCD-SX910/X710 series cameras use the same automatic bus synchronization system. The 1394 bus is a shared resource with finite bandwidth. The number of cameras that can be simultaneously is limited by the ISO bandwidth available (~32 MBytes/sec) and ISO channels (4-8 depending on your computer 1394 interface). Bandwidth is allocated based on the resolution and frame rate selected for the camera. To reduce the bandwidth for a camera, reduce the output image size and/or the frame rate.

For instance, if a camera is to transmit 1280×960 in YUV4:2:2 at 7.5 fps, approximately 18.4 MBytes/sec; more than half the available bandwidth. Reducing the frame rate to 3.75 fps reduces the bandwidth to approximately 9.2 MBytes/sec allowing 3 cameras to transmit simultaneously.

CPU operation timing can cause jitter in the 1394 bus synchronization of approximately 4 microseconds. External hardware (trigger) synchronization can be used to ensure further accuracy. To synchronize cameras on different 1394 busses, use a common hardware trigger to all the cameras.

Exposure Out

A signal that indicates an exposure time is output from pin 1 on the 4-pin connector on the rear panel. When the hardware trigger feature is used, the signal above is not output. The output is the open-collector type.

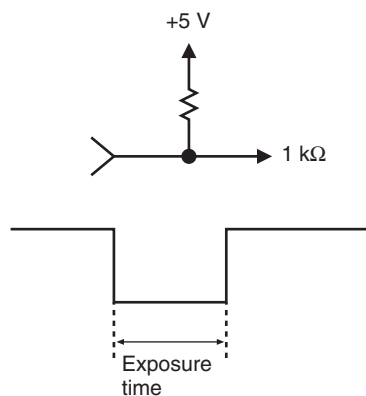
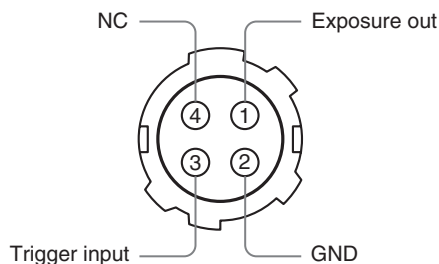

The LOW period that is given by an output wave form is an approximate guideline. It does not correspond exactly to the actual exposure time.

Camera Command Status Register

This camera complies with the IIDC 1394-based Digital Camera Specification, version 1.30 (hereinafter referred to as IIDC v1.30).

The standards document can be purchased from 1394TA (the 1394 Trade Association). Because it is very helpful in understanding the explanations in this Technical Manual, we recommend that you purchase a copy of IIDC v1.30.

Memory Map

1394 devices have a 64-bit address space. The upper 10 bits show the bus ID (0~1023), and the next six bits show the node ID (0~63). The IIDC standard requires the next 20 bits to be 1.

|---BusID---|NodeID| -----Must be 1----- | ----Address used by the camera---- |
 bbbbbbb | bbnnnnn | 11111111 | 11111111 | 11110000 | 11110000 | 00000000 | 00000000

The remaining 28 bits can be allocated to the camera as addresses, but in reality, the first 4 bits are fixed at 0, so the largest number of bits that can be allocated to the camera as address space is 24 bits.

The bus and node IDs may be changed if the topology is restructured because of bus reset, so only the least significant 32 address bits are shown in this Technical Manual.

Address	Register
F0000000	Base address
F0000400	ConfigROM area
F0F00000	Base addresses for camera commands
F0F00000	CameraInitialize
F0F00100	Video Format Inq
F0F00180	Video Mode Inq
F0F00200	Frame Rate Inq
F0F002E0	Format7 CSR Inq
F0F00400	Basic Func Inq
F0F00500	Feature Element Inq
F0F00600	Isochronous Control register
F0F0071C	AbsoluteControlCSR Inq for Shutter
F0F00800	FeatureControl
F0F00970	AbsoluteControlCSR for Shutter
F0F10000	Format7Mode0 CSR
F0F30000	Access Control Register
F0F40000	Memory Shot control
F0F50000	User Memory

ConfigROM

	Offset	0-7	8-15	16-23	24-31	
Bus Info Block	400h	04	1F	ROM CRC		
	404h	31	33	39	34	
	408h	20	FF	60	00	
	40ch	08	00	46	02	NodeVendorID/ChipID-Hi
	410h	00	0F	00	01	ChipID-Lo
Root	414h	0004		CRC		
Directory	418h	03	08	00	46	ModuleVendorID
	41ch	0C	00	83	C0	
	420h	8D	00	00	02	IndirectOffset
	424h	D1	00	00	04	UnitDirectoryOffset

With the exception of bits 8 to 15 of the 400h offset address field, the length of the entire ConfigROM field is made up of 1Fh Quadlets. So ConfigROM from 400h to 47Fh is 128 bytes.

Offset address 420h and key code 8Dh indicate a NodeUniqueID Leaf offset, but in 1394a-2000, this field has been eliminated. To ensure compatibility with

previous models, this field has been retained in this model, but in writing drivers and software applications, be sure to ignore this field. For a NodeUniqueID, use NodeVendorID/ChipID-Hi + ChipID-Lo in BusInfoBlock.

The offset address of UnitDirectory is required to be $424h + 000004h * 4 = 434h$

	Offset	0-7	8-15	16-23	24-31	
Unit	434h	0003		CRC		
Directory	438h	12	00	A0	2D	UnitSpecID
	43Ch	13	00	01	02	UnitSoftwareVersion
	440h	D4	00	00	01	UnitDependentDirectory Offset

For offset address 434h, the length of the UnitDirectory is 3 Quadlets. UnitSpecID (00A02Dh) conforms to 1394TA standards. UnitSoftwareVersion (000102h) conforms to the IIDC standard, v 1.30.

The offset address of UnitDependentInfo is required to be

$$440h + 000001h * 4 = 444h$$

	Offset	0-7	8-15	16-23	24-31	
Unit	444h	0003		CRC		
Dependent	448h	40	3C	00	00	CommandRegsBase
Info	44ch	81	00	00	02	VendorNameLeaf
	450h	82	00	00	05	ModelNameLeaf

For offset address 444h, the length of the UnitDependentInfo is 3 Quadlets.

The offset address of VendorNameLeaf is required to be

$$44Ch + 000002h * 4 = 454h$$

CommandRegsBase is the base address of the camera control register.

$$F0000000h + 3c0000h * 4 = F0F00000h$$

The offset address of ModelNameLeaf is required to be

$$450h + 000005h * 4 = 464h$$

VendorNameLeaf

	Offset	0-7	8-15	16-23	24-31	
Vendor	454h	0003		CRC		
Name	448h	00	00	00	00	
Leaf	44ch	00	00	00	00	
	450h	53	4F	4E	59	“SONY”

For offset address 454h, the length of the VendorNameLeaf field is 3 Quadlets.

The subsequent 8 bytes are fixed at 00.

After that, the four characters for “SONY” are entered.

ModelNameLeaf

	Offset	0-7	8-15	16-23	24-31	
Model	464h	0006		CRC		
Name	468h	00	00	00	00	
Leaf	46ch	00	00	00	00	
	470h	44	46	57	2D	“DFW-”
	474h	53	58	39	31	“SX91”
	478h	30	20	76	31	“0 v1”
	47Ch	2E	30	32	41	“.02A”

For offset address 464h, the length of the ModelNameLeaf field is 6 Quadlets.

The subsequent 8 bytes are fixed at 00.

For the DFW-SX910, the 16 characters “DFW-SX910 v1.02A” come next. For the DFW-X710, the 15 characters are “DFW-X710 v1.02A”.

Model names are subject to change with the upgrade of firmware.

Control Base Address

Every register address is decided based on the base address found in the CommandRegsBase field of ConfigROM. F0F00000h is the control base address on this camera.

Verifying Supported Video Modes

First, we will find out what video formats are supported.

Address	Data	
	DFW-SX910	DFW-X710
F0F00100h	E1000000h	C1000000h

We find that the DFW-SX910 supports Format0/1/2/7, and the DFW-X710 supports Format0/1/7.

Next, for each format, we will find out which video modes are supported.

Format0

Address	Data	
	DFW-SX910	DFW-X710
F0F00180h	74000000h	74000000h

We find video modes 1, 2, 3, and 5 of Format0 are supported.

Format1

Address	Data	
	DFW-SX910	DFW-X710
F0F00184h	B4000000h	B4000000h

We find video modes 0, 2, 3 and 5 of Format1 are supported.

Format2 (DFW-SX910 only)

Address	Data	
	DFW-SX910	DFW-X710
F0F00188h	A0000000h	-

We find video modes 0 and 2 of Format2 are supported.

Format7

Address	Data	
	DFW-SX910	DFW-X710
F0F0019Ch	C0000000h	80000000

We find that the DFW-SX910 supports video modes 0 and 1 of Format7, and the DFW-X710 supports video mode 0 of Format7.

Next, for each video mode, we will find out which frame rates are supported.

Address	Data	
	DFW-SX910	DFW-X710
F0F00204h (Format0Mode1)	60000000h	70000000h
F0F00208h (Format0Mode2)	60000000h	70000000h
F0F0020Ch (Format0Mode3)	60000000h	70000000h
F0F00214h (Format0Mode5)	60000000h	70000000h
F0F00220h (Format1Mode0)	60000000h	70000000h
F0F00228h (Format1Mode2)	20000000h	30000000h
F0F0022Ch (Format1Mode3)	E0000000h	F0000000h
F0F00234h (Format1Mode5)	E0000000h	F0000000h
F0F00240h (Format2Mode0)	E0000000h	-
F0F00248h (Format2Mode2)	E0000000h	-

Based on the data above, the formats, modes, and frame rates supported are shown in the tables on the next page.

Video modes supported (except for Format7)

DFW-SX910

Format	Mode	Image Size	Color Coding	Frame Rate			
				15	7.5	3.75	1.875
0	1	320 × 240	YUV4:2:2		○	○	–
	2	640 × 480	YUV4:1:1		○	○	–
	3	640 × 480	YUV4:2:2		○	○	–
	5	640 × 480	Mono8		○	○	–
1	0	800 × 600	YUV4:2:2		○	○	–
	2	800 × 600	Mono8		○	–	–
	3	1024 × 768	YUV4:2:2		○	○	○
	5	1024 × 768	Mono8		○	○	○
2	0	1280 × 960	YUV4:2:2		○	○	○
	2	1280 × 960	Mono8		○	○	○

DFW-X710

Format	Mode	Image Size	Color Coding	Frame Rate			
				15	7.5	3.75	1.875
0	1	320 × 240	YUV4:2:2	○	○	○	–
	2	640 × 480	YUV4:1:1	○	○	○	–
	3	640 × 480	YUV4:2:2	○	○	○	–
	5	640 × 480	Mono8	○	○	○	–
1	0	800 × 600	YUV4:2:2	○	○	○	–
	2	800 × 600	Mono8	○	○	–	–
	3	1024 × 768	YUV4:2:2	○	○	○	○
	5	1024 × 768	Mono8	○	○	○	○

Video Mode Settings

Select the video mode you want to use from the tables, and make the required settings.

As examples, the register settings for Format2, Mode0, and a frame rate of 7.5 fps for the DFW-SX910, and Format1, Mode3, and a frame rate of 15 fps for the DFW-X710, are shown.

In addition, an isochronous transfer speed of 400 Mbps and isochronous channel 0 are used in these examples. Normally, set the isochronous transfer speed to 400 Mbps.

When multiple cameras are used simultaneously, set different isochronous channels for each one.

Address	Data	
	DFW-SX910	DFW-X710
F0F00600h (Frame Rate)	40000000h	60000000h
F0F00604h (Video Mode)	00000000h	60000000h
F0F00608h (Video Format)	40000000h	20000000h
F0F0060ch (IsoChannel/ IsoSpeed)	02000000h	02000000h

Starting/Stopping Video Transfer (Continuous Shot)

In the device driver, after the preparations for receiving isochronous data are made, video transfer starts when the following commands are issued.

Address	Data
F0F00614h	80000000h

When the following command is issued, video transfer stops.

Address	Data
F0F00614h	00000000h

One Shot and Multi Shot

This camera supports both One Shot and Multi Shot commands. With a One Shot command, after outputting just one single-frame image, the camera enters an “idling” state. With a Multi Shot command, the camera enters the “idling” state after outputting exactly the specified number of images.

One Shot

Address	Data
F0F0061Ch	80000000h

Multi Shot

Address	Data
F0F0061Ch	4000nnnnh

nnnn indicates the number of frames to be output. You can specify any number between 0001h ~ FFFFh (1~65535). If 0000h is specified, you can think of it as 1 being set instead.

Execution of Continuous Shot, One Shot, and Multi Shot are prioritized as follows. When a command with higher priority is being executed, one with a lower priority is ignored.

Priority	Command
1	Continuous Shot
2	One Shot
3	Multi Shot

Memory Channel Operation

Save

Selecting the Memory Channel used to save the data

Address	Data	Operation
F0F00620h	10000000h	Selects Ch 1.
	20000000h	Selects Ch 2.

Saving data

Address	Data	Operation
F0F00618h	80000000h	Saves the current setting.

Load

Address	Data	Operation
F0F00624h	00000000h	Loads the default settings.
	10000000h	Loads the setting information in Ch 1.
	20000000h	Loads the setting information in Ch 2.

The settings of the camera features and the video mode can be stored.

The camera memorizes the channel most recently used to read out the setting information using nonvolatile memory. Then, the information in that channel will be loaded when the power is turned on the next time.

The video mode settings are loaded only when the power is turned on. If you read out Memory Channels during operation, only the settings of the camera features are loaded.

The value of Pan/Tilt depends on the video mode settings. If you change the video mode after carrying out the Save command, the value of Pan/Tilt may not be loaded correctly.

Feature Controls (Complies with the IIDC Standard)

This camera supports the following features.

Brightness	Makes fine adjustment of the black level possible.
Auto Exposure	Controls the target video level value when Shutter/Gain is set to Auto.
Sharpness	Adjusts the picture sharpness.
White Balance	Adjusts the color balance of the camera to ensure that a white subject appears white in the video image.
Hue	Adjusts color tones.
Saturation	Adjusts color intensity.
Gamma	Sets a gamma curve.
Shutter	Controls the exposure time. To control this feature, you can use both relative control values from 1/100,000 of a second to 16 seconds, allocated from 3 to 1150, and absolute value control, with values from 1/100,000 of a second to 17.5 seconds, set continuously.
Gain	Controls the gain in the range from 0 dB to 18 dB. The unit of the adjustment is approximately 0.035 dB.
Trigger	Controls external triggers. This feature supports Trigger Mode 0 and 1. A software trigger feature is also supported.
Pan/Tilt	Sets CCD output range (both horizontal (Pan) and vertical (Tilt)). The video mode predetermines the variable range. Not available in Partial Scan mode (Format7/Mode0).
Optical Filter	Sets a preset value for White Balance. Setting values of 3200 K and 5600 K are available.

Before sending a command, check the predetermined variable range and check whether the feature supports Auto mode.

considerably depending on the video mode. After switching video mode, check the variable range for Pan/Tilt.

Note that variable ranges for Pan/Tilt differ

Address	Data	Bit* ¹⁾	
F0F00500h (Brightness)	8900007Fh	0	This feature exists.
		4	The value can be read out.
		7	Manual setting can be selected.
		8-19	Min. 0
		20-31	Max. 127
F0F00504h (Auto Exposure)	8905A073h	0	This feature exists.
		4	The value can be read out.
		7	Manual setting can be selected.
		8-19	Min. 90
		20-31	Max. 115
F0F00508h (Sharpness)	89000007h	0	This feature exists.
		4	The value can be read out.
		7	Manual setting can be selected.
		8-19	Min. 0
		20-31	Max. 7
F0F0050Ch (White Balance)	9B700900h	0	This feature exists.
		3	One Push Auto mode can be selected.
		4	The value can be read out.
		6	Auto setting can be selected.
		7	Manual setting can be selected.
		8-19	Min. 1792
		20-31	Max. 2304
F0F00510h (Hue)	890530ADh	0	This feature exists.
		4	The value can be read out.
		7	Manual setting can be selected.
		8-19	Min. 83
		20-31	Max. 173
F0F00514h (Saturation)	890001FFh	0	This feature exists.
		4	The value can be read out.
		7	Manual setting can be selected.
		8-19	Min. 0
		20-31	Max. 511
F0F00518h (Gamma)	89080082h	0	This feature exists.
		4	The value can be read out.
		7	Manual setting can be selected.
		8-19	Min. 128
		20-31	Max. 130
F0F0051Ch (Shutter)	CB00347Eh	0	This feature exists.
		1	Absolute value control possible
		4	The value can be read out.
		6	Auto setting can be selected.
		7	Manual setting can be selected.
		8-19	Min. 3
		20-31	Max. 1150

*¹⁾ According to the IEEE 1394 specifications, the most significant bit is shown as 0.

Address	Data	Bit* ¹⁾	
F0F00520h (Gain)	8B046227h	0	This feature exists.
		4	The value can be read out.
		6	Auto setting can be selected.
		7	Manual setting can be selected.
		8-19	Min. 70
		20-31	Max. 551
F0F00530h (Trigger)	8C81C000h	0	This feature exists.
		4	The value can be read out.
		5	This feature can be switched ON and OFF.
		8	Trigger Source0 exists.* ²⁾
		15	Software Trigger Mode exists.* ²⁾
		16	Trigger Mode0 exists.
F0F00584h (Pan) F0F00584h (Tilt)	89*****	0	This feature exists.
		4	The value can be read out.
		7	Manual setting can be selected.
		8-19	Min. (Depends on the video mode.)
		20-31	Max. (Depends on the video mode.)
F0F0058Ch (Optical Filter)	89000001h	0	This feature exists.
		4	The value can be read out.
		7	Manual setting can be selected.
		8-19	Min. 0
		20-31	Max. 1

*¹⁾ According to the IEEE 1394 specifications, the most significant bit is shown as 0.

*²⁾ These features comply with IIDC v1.31.

Actual control can be carried out by setting registers from F0F00800 onward.

ddd indicates the control value expressed as a 12 bit hexadecimal number.

xxx indicates that any setting made will be ignored.

Brightness control

Address	Data	
F0F00800	82000ddd	Adjusts the black level.

AE reference control

Address	Data	
F0F00804	82000ddd	Sets the AE reference value.

Sharpness control

Address	Data	
F0F00808	82000ddd	Adjusts the picture sharpness. 0 (Soft)↔7 (Sharp)

White Balance control

Address	Data	
F0F0080C	82uuuvvv	Adjusts White Balance using relative values. uuu: Blue component vvv: Red component
	83xxxxxx	Sets Auto White Balance.
	86xxxxxx	Adjusts White Balance automatically once, then the feature turns to manual mode.

Hue control

Address	Data	
F0F00810	82000ddd	Adjusts color tones.

Saturation control

Address	Data	
F0F00814	82000ddd	Adjusts color intensity.

Gamma control

Address	Data	
F0F00818	82000ddd	Sets the gamma compensation. 82000080: Deactivates the gamma feature. 82000081: Activates the gamma feature (gamma curve 1). 82000082: Activates the gamma feature (gamma curve 2).

Shutter (exposure time) control

Address	Data	
F0F0081C	82000ddd	Controls shutter using the manually set relative value.
	83000xxx	Sets Shutter to AUTO.
	C2000xxx	Controls shutter using the absolute control value.
F0F00970 (See page 26.)	Indicates an arbitrary value using a 32-bit floating point number.	After F0F0081C has been set to Absolute value control, set exposure time using this register.

Gain control

Address	Data	
F0F00820	82000ddd	Sets Gain manually.
	83000xxx	Sets Gain to AUTO.

Trigger control

Address	Data	
F0F00830	82000000	Sets Hardware Trigger Mode0.
	82010000	Sets Hardware Trigger Mode1.
	82E00000	Sets Software Trigger Mode0. *
	82E10000	Sets Software Trigger Mode1. *
F0F0062C*	80000000	Outputs a software trigger. In Trigger Mode0, automatically reset to 0 when exposure ends.
	00000000	In Trigger Mode1, ends exposure if "0" is set.

* These features comply with IIDC v1.31.

Pan/Tilt control

Address	Data	
F0F00884	82000ddd	Sets Pan manually.
F0F00888	82000ddd	Sets Tilt manually.

Optical Filter control

Address	Data	
F0F0088C	82000ddd	Sets preset value for White Balance. 82000000: value for 3200 K 82000001: value for 5600 K

The formula for the absolute value shutter control register address**Absolute value shutter control CSR offset address**

Address	Data	
F0F0071C	003C025C	Absolute value shutter control CSR offset

The register address for absolute value shutter control is given by the following formula.

$$F0000000h + 003C025Ch * 4 = F0F00970h$$

Feature Controls (IIDC Extended)

This camera supports the following extended features.

PAINT	Sets the reference point of the White Balance to other than white.
Memory Shot	Stores an image on the frame memory and outputs it asynchronously.
User Memory	A 256-byte memory area reserved for users. The information in this area will be preserved even if the power to the camera is turned off.

To control these extended features (Vendor Unique Features), use the Access Control Register defined by the IIDC standard.

The formula for the ACR offset address

First, we will find out whether the camera supports Vendor Unique Features.

F0F00400h (BASIC_FUNC_INQ)	80001802h	0	Vendor Unique Features are supported.
		19	One Shot can be transmitted.
		20	Multi Shot can be transmitted.
		28-31	2: Memory channel 2

F0F00480h (Advanced_Feature_Inq)	003CC000h	ACR offset
-------------------------------------	-----------	------------

The Access Control Register address is given by the following formula.

$$F0000000h + 003CC000h * 4 = F0F30000h$$

PAINT Control

Issue the following commands using BlockWrite or QuadletWrite.

```
F0F30000h  <= 08004600h
F0F30004h  <= 0002FFFFh
F0F30008h  <= UUUUVVVVh
```

Specify UUUU and VVVV within the range from -4 to +4 using 16-bit signed integers.

The values which you set will be preserved even if the power to the camera is turned off. To restore the initial value, set UUUU and VVVV to 0.

Memory Shot Control

The following instructions are provided to allow you to operate the camera in the external synchronization mode.

- 1 Stop the video transmission.
- 2 Set camera features, such as video mode, frame rate, etc.
If you change the image size to a smaller one, a higher frame rate will be available.
- 3 Issue the following commands using BlockWrite or QuadletWrite.

```
F0F30000h  <= 08004600h
F0F30004h  <= 0010FFFFh
F0F30008h  <= 80000000h
```

Then, the Memory Shot feature is activated.

- 4 Set the external trigger feature to ON.

```
F0F00830h  <= 82000000h
```

- 5 Issue the start capturing command.

```
F0F40000h  <= 0100nnnnh
```

nnnn indicates the number of frames to be captured. When the specified number of frames is captured or the memory fills up with data, the capture mode will be released. To find the number of the frames captured, read out F0F40000h. The end flag shows that the capture mode has been released.

```
0101000Ah  When the mode is released after 10 frames are
             captured, bit 16 indicates an end flag.
```

- 6 Set the external trigger feature to OFF.

```
F0F00830h  <= 80000000h
```

- 7 Issue the video start command.

The camera outputs the frames in the memory area and then enters the “idling” state. The frames are output sequentially in the captured order. You cannot specify a frame to be output on a random basis.

- 8 If output ends, issue the video stop command. This step cannot be skipped.

One procedure is completed. You can perform the operation from step 4 over again.

To exit from the Memory Shot mode and return to the normal mode

Issue the following commands using BlockWrite or QuadletWrite.

```
F0F30000h  <= 08004600h
F0F30004h  <= 0010FFFFh
F0F30008h  <= 00000000h
```

If you perform the procedure with a camera of which the external Trigger Mode is set to OFF

Capturing starts at the moment you issue the command in step 5.

User Memory Control

Issue the following commands using BlockWrite or QuadletWrite.

```
F0F30000h  <= 08004600h
F0F30004h  <= 0011FFFFh
F0F30008h  <= 80000000h
```

The user memory area is opened. User Memory is mapped to F0F50000h-F0F500FFh.

QuadletRead/Write and BlockRead/Write are available.

If you issue the following commands using BlockWrite or QuadletWrite, the user memory area is locked and will be inaccessible.

```
F0F30000h  <= 08004600h
F0F30004h  <= 0011FFFFh
F0F30008h  <= 00000000h
```

Notes on ACR access

The Access Control Register is managed by the time-out control. A series of commands must be completed within a time-out duration. The time-out duration is specified using the ACR access commands.

```
F0F30000h <= 08004600h
             Access control key (32-bit)
F0F30004h <= 0011FFFFh
             Access control key (16-bit) +
             'F' + time-out (12-bit)
F0F30008h <= 80000000h
             Control commands
```

Time-out duration is specified using 12-bit values, and the unit is 1 ms. FFF indicates 4095 ms.

Partial Scan Operations

Partial scan can be set using either the SettingBit or IIDC v1.20 interchange.

An example of the setting procedure (In the case of a DFW-SX910)

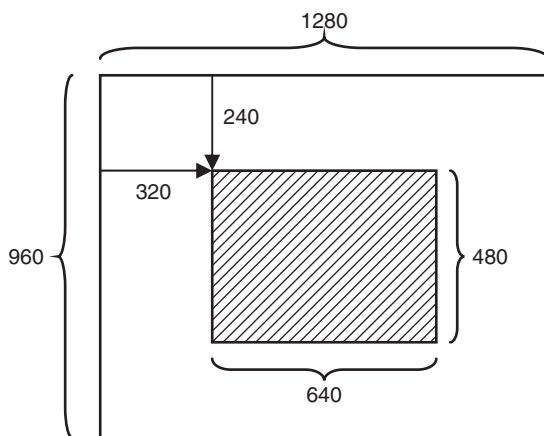

When shooting the center of the whole screen with a screen size of 640×480 , and with color coding set to YUV4:2:2, the packet size set to maximum in order to capture the image at the highest speed.

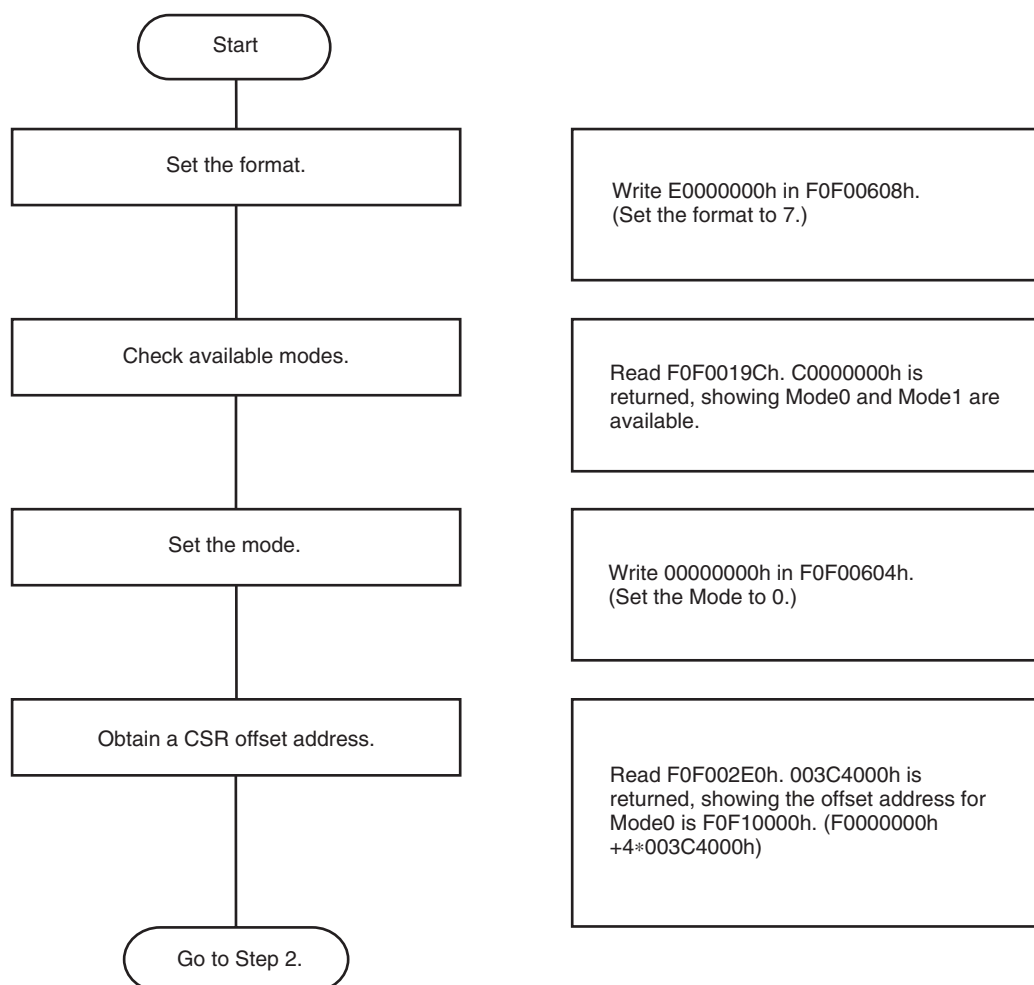

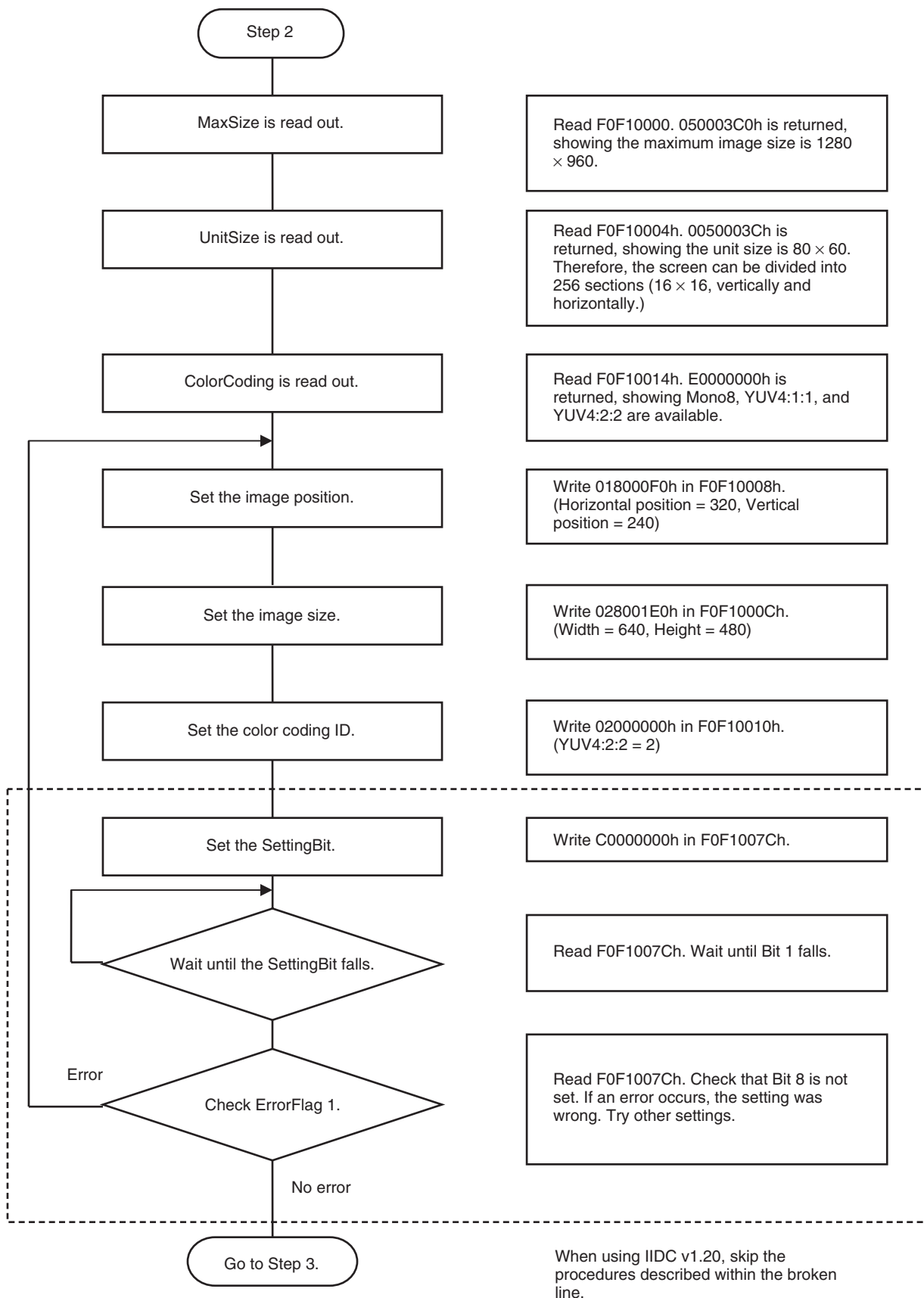

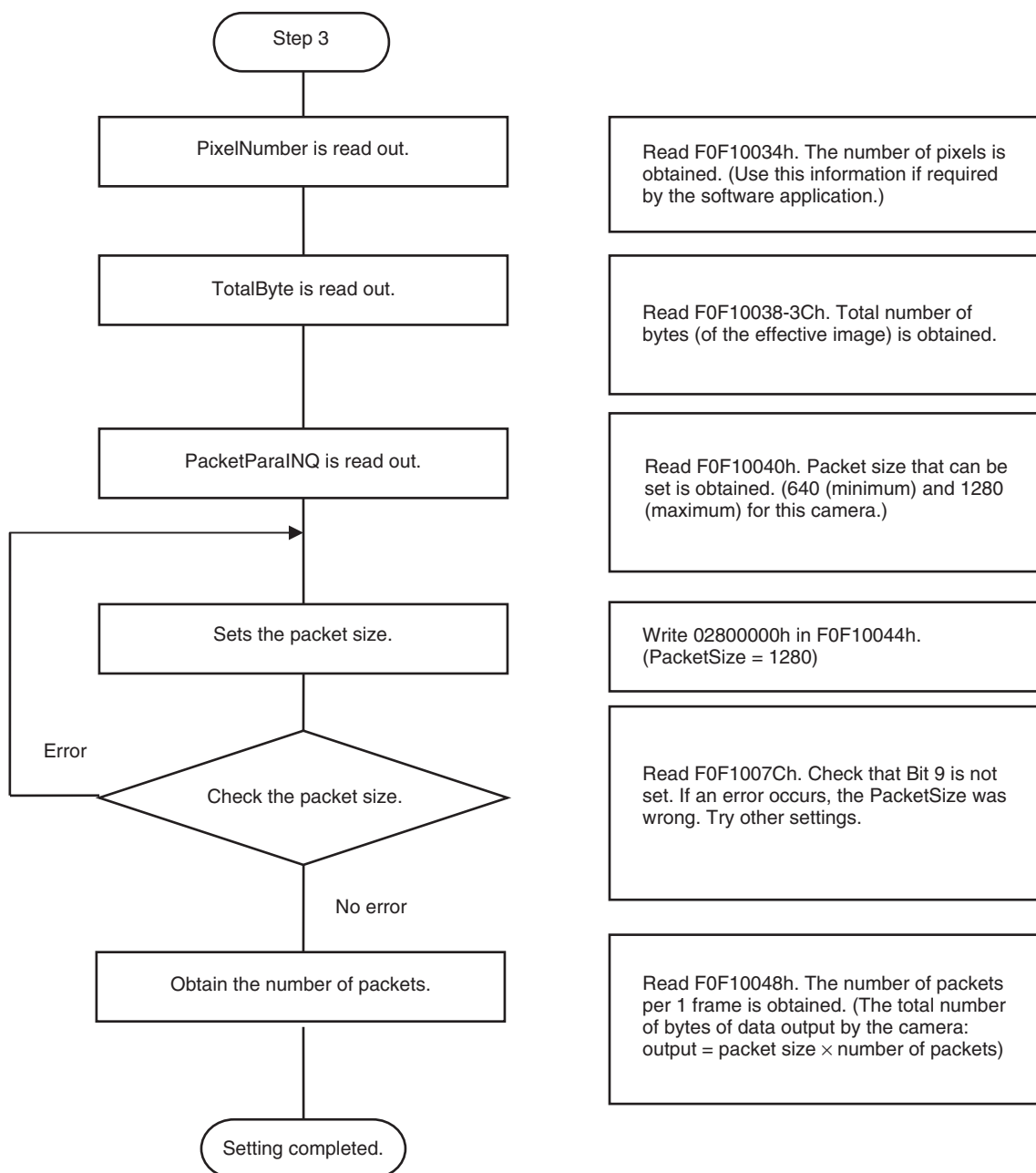

Image transmission is now ready. Send a video start command to output images.
The camera does not support RecBytePerPacket.

Notes on the Camera Operations

1. If a Frame rate decrease.

Frame rate may decrease depending on your shutter settings.

- a. When a series of images is output, the instant when the exposure time is shorter than one frame, and the exposure time setting is shortened using the shutter.

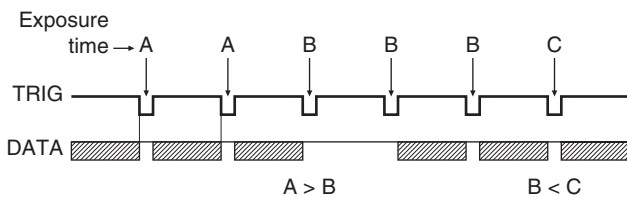

In this case, the camera tends to skip 1 frame image, resulting in a decrease in the frame rate. Keep this in mind when using an application that switches exposure time frequently.

- b. With a long exposure
In long exposure mode, the exposure time is set longer than the image transmission cycle. In this case, frame rate decreases according to the exposure time.

2. When using Trigger Mode

When this camera is set to accept a trigger at the fastest possible timing, it can accept overlap of the next trigger signal in the midst of video transmission. For this reason, a trigger inhibition period is not available. Thus, if a trigger signal is input before the CCD can change to the state where it can accept exposures, multiple exposures can occur, and it cannot capture the correct image. Make sure that the following conditions are met when the trigger is activated.

(However, partial activation can be used if the following conditions are exceeded. Refer to the table on pages 37 and 38.)

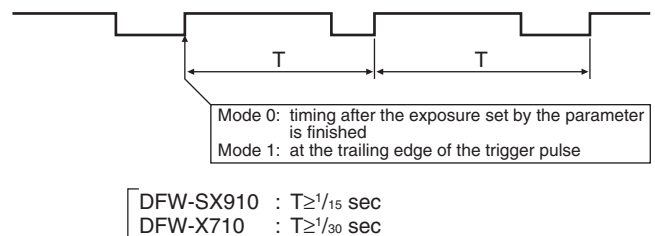

3. When AE (Auto Exposure) is not available

The camera loads the AE function that controls Gain and Shutter automatically. However, the function works properly in the following standard settings only.

Standard settings

DFW-SX910 Video Format: 2
 Video Mode: 0
 Frame Rate: 7.5 fps
 Trigger: OFF

DFW-X710 Video Format: 1
 Video Mode: 3
 Frame Rate: 15 fps
 Trigger: OFF

When other modes are set, activating the AE function is possible, however, normal operation of the function is not guaranteed.

In Trigger Mode—AE works properly when the video format is set to the standard setting and the trigger cycle is set to the same as that of the video format.

4. Auto shutter control and absolute value shutter control

The auto shutter control function cannot be used in the Absolute value control mode. When Shutter is set to Auto, the Absolute value control mode is automatically canceled.

5. Issues to be considered with partial activation

With partial activation, high-speed operation of the CCD occurs.

If strong light comes into the image at the same time, there may be some influence at the edges of the image.

In such a case then, adjust the lens so that only the appropriate amount of light is allowed.

6. About the address range available for BlockWrite operations

The camera performs BlockWrite operations against consecutive registers. However, the range of the addresses stored in these registers are limited.

Available address ranges for BlockWrite operations	Functions
F0F00600h – F0F00614h	Frame rate/Video mode/Video format/Isochronous channel/Isochronous speed/Isochronous_Enable
F0F00800h – F0F008FCh	Feature control
F0F30000h – F0F30008h	ACR
F0F50000h – F0F500FCh	User memory

If BlockWrite operations are performed outside the ranges listed above, an address error will occur.

Meanwhile, the camera can perform BlockRead operations for any sequence of consecutive registers even though the registers are not available for BlockWrite operations.

In Format7 CSR, for example, BlockWrite operations are prohibited because Format7 CSR requires a process for setting the register. However, BlockRead is possible in Format7 CSR.

7. Note on the isochronous control register

The BlockWrite operations are available in the range F0F00600h to F0F00614h. However, setting the video mode in this range is not recommended because it may influence the variable range available for the features.

Following the process listed below is recommended for setting the isochronous control register.

- Set the isochronous channel/isochronous speed (F0F0060Ch)
- Set the video format (F0F00608h)
- Set the video mode (F0F00604h)
- Set the frame rate (F0F00600h)
- Confirm the variable range for the various features (F0F00500-F0F005FCh)
- Set the features (as needed) (F0F00800-F0F008FCh)
- Prepare for video data capture
- Video start (F0F00614h)

8. Converting Y/Cr/Cb to R/G/B

The camera outputs digital Y/Cr/Cb data. To convert the digital Y/Cr/Cb data to R/G/B data, use following formula.

$$R \approx 1.4022Cr + Y$$

$$B \approx 1.7710Cb + Y$$

$$G \approx Y - 0.7144Cr - 0.3457Cb$$

9. Timing of the change in feature setting

The change in feature setting will take effect when the next exposure starts. When you change the shutter setting during a long exposure, you need to note that the change in shutter setting does not cancel the current exposure. The current exposure will complete with the previous shutter setting.

If you intend to start the exposure with a new shutter setting immediately, either stop the output, then change the setting and start the output again, or change the setting, then stop the output and start it again.

10. Timing of the video transmission command and that of the output

In Continuous Shot and Multi Shot modes, the bus synchronization system works automatically.

Therefore, the timing of the acceptance of a command does not synchronize with that of the output.

On the other hand, in One Shot mode or long exposure mode, the bus synchronization system does not work.

Therefore, the camera starts the exposure immediately after the video transmission command is accepted, and the video will be output when the exposure is complete.

Timing Between External Trigger Signal and Video Signal Output

When the Trigger Mode is set to 0, the timing will be as follows.

After the exposure time is set by the Shutter command (CSR F0F0081Ch), VD pulses will be generated inside the camera.

Images will be isochronously output after the A period from the falling edge of the VD.

(The following figure shows an example where the frame rate is 7.5 fps for the DFW-SX910, and 15 fps for the DFW-X710.)

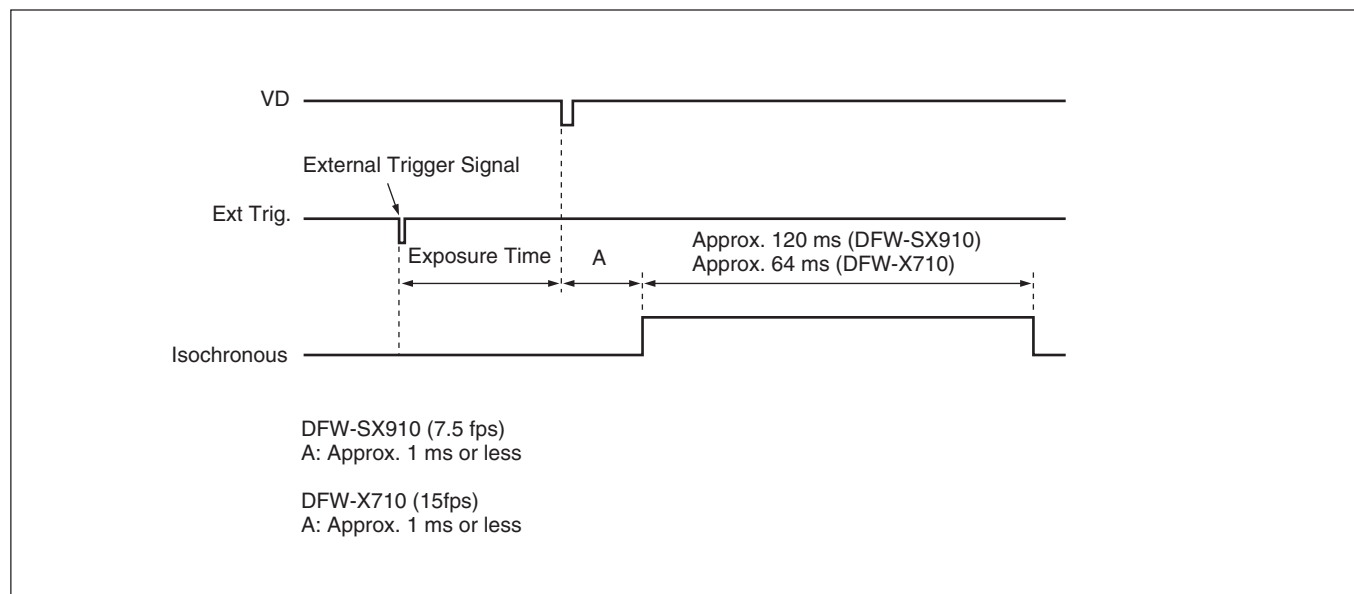

The timing when the Trigger Mode is set to 1 is the same as above. In this case, the exposure time is defined by the Trigger pulse width.

Specifications

Image sensor		Shutter	1/100,000 to 17.5 s (Absolute value control possible)
DFW-SX910	$\frac{1}{2}$ -type progressive scan IT transfer CCD	Gain	Auto/Manual (0 to +18 dB)
DFW-X710	$\frac{1}{3}$ -type progressive scan IT transfer CCD	External trigger shutter	Available (Trigger Mode0/1)
Number of effective pixels		Partial scan function (Smallest unit)	
DFW-SX910	Approx. 1,450,000 1392 (H) \times 1040 (V)	DFW-SX910	80 (H) \times 60 (V)
DFW-X710	Approx. 800,000 1034 (H) \times 779 (V)	DFW-X710	64 (H) \times 48 (V)
Unit cell size	4.65 μ m (H) \times 4.65 μ m (V)	Power supply/Power consumption	DC +8 to +30 V (from IEEE1394 cable)
Interface format	IEEE1394–1995	Power consumption	3.5 W (12 V)
Transfer speed	400/200 Mbps	Operating temperature	–5 to +45°C
Protocol	IIDC 1394-based Digital Camera Specification Version 1.30 Compliant	Storage temperature	–20 to +60°C
Image format (fixed size)		Operating relative humidity	20 to 80% (No condensation)
DFW-SX910	1280 \times 960 YUV (4:2:2)/Mono8 1024 \times 768 YUV (4:2:2)/Mono8 800 \times 600 YUV (4:2:2)/Mono8 640 \times 480 YUV (4:2:2/4:1:1)/Mono8 320 \times 240 YUV (4:2:2)	Storage relative humidity	20 to 95% (No condensation)
DFW-X710	1024 \times 768 YUV (4:2:2)/Mono8 800 \times 600 YUV (4:2:2)/Mono8 640 \times 480 YUV (4:2:2/4:1:1)/Mono8 320 \times 240 YUV (4:2:2)	Vibration resistance	10 G (20 to 200 Hz, 20 minutes for each direction-X, Y, Z)
Frame rate (depends on the image format)		MTBF	59549 Hrs (Approx. 6.8 years)
DFW-SX910	7.5 to 1.875 fps	Shock resistance	70 G
DFW-X710	15 to 1.875 fps	Dimensions	44 (W) \times 33 (H) \times 116 (D) mm
Image format (Format7) (for Partial scan)		Mass	250 g
DFW-SX910	1280 \times 960 YUV (4:2:2/4:1:1)/Mono8	Accessories	IEEE1394 cable (1) Lens mount cap (1) Operating Instructions (1)
DFW-X710	1024 \times 768 YUV (4:2:2/4:1:1)/Mono8		
Partial scan function	16 \times 16 (256 sections)		
Lens mount	C-mount		
Flange back	17.526 mm		
Minimum illumination	20 lx (F0.95, Gain: +18 dB)		
White balance	One Push/ATW/preset (3200 K, 5600 K)/manual		
Hue	Adjustable		
Saturation	Adjustable		
Brightness	Adjustable		
Gamma	Variable		
CCD Iris	ON/OFF		

Video modes supported

DFW-SX910

Fixed format

Format	Mode	Image Size	Color Coding	Frame Rate			
				15	7.5	3.75	1.875
0	1	320 × 240	YUV4:2:2		○	○	–
	2	640 × 480	YUV4:1:1		○	○	–
	3	640 × 480	YUV4:2:2		○	○	–
	5	640 × 480	Mono8		○	○	–
1	0	800 × 600	YUV4:2:2		○	○	–
	2	800 × 600	Mono8		○	–	–
	3	1024 × 768	YUV4:2:2		○	○	○
	5	1024 × 768	Mono8		○	○	○
2	0	1280 × 960	YUV4:2:2		○	○	○
	2	1280 × 960	Mono8		○	○	○

Free format

Format	Mode	Image Size	Color Coding	Partial Scan	Frame Rate
7	0	1280×960	Mono8	○ (16×16)	Not specified
	0	1280×960	YUV4:1:1	○ (16×16)	Not specified
	0	1280×960	YUV4:2:2	○ (16×16)	Not specified
	1	1280×960	Mono8	×	7.5/3.75 fps
	1	1280×960	YUV4:1:1	×	7.5/3.75 fps
	1	1280×960	YUV4:2:2	×	7.5/3.75 fps
	1	1280×960	RAW8	×	7.5/3.75 fps

DFW-X710

Fixed format

Format	Mode	Image Size	Color Coding	Frame Rate			
				15	7.5	3.75	1.875
0	1	320 × 240	YUV4:2:2	○	○	○	–
	2	640 × 480	YUV4:1:1	○	○	○	–
	3	640 × 480	YUV4:2:2	○	○	○	–
	5	640 × 480	Mono8	○	○	○	–
1	0	800 × 600	YUV4:2:2	○	○	○	–
	2	800 × 600	Mono8	○	○	–	–
	3	1024 × 768	YUV4:2:2	○	○	○	○
	5	1024 × 768	Mono8	○	○	○	○

Free format

Format	Mode	Image Size	Color Coding	Partial Scan	Frame Rate
7	0	1024×768	Mono8	○ (16×16)	Not specified
	0	1024×768	YUV4:1:1	○ (16×16)	Not specified
	1	1024×768	YUV4:2:2	○ (16×16)	Not specified

Notes on the frame rates in Partial Scan Mode

The following table shows examples of frame rates in Partial Scan Mode. Note that the values in the table are given as examples, as the frame rate varies depending on exposure times or areas you have specified.

DFW-X710

With Trigger OFF, Packet Size = 3072, and video mode = YUV4:2:2

Image Width	Image Height	Shutter=182 (33.1 ms)		Shutter=3 (9 μ s)	
		Frame time (ms)	Frame rate (fps)	Frame time (ms)	Frame rate (fps)
1024	48	49.0	20.4	16.0	62.5
1024	96	52.1	19.2	19.0	52.6
1024	144	54.9	18.2	22.0	45.5
1024	192	58.8	17.0	26.0	38.5
1024	240	62.1	16.1	29.0	34.5
1024	288	64.9	15.4	31.9	31.3
1024	336	69.0	14.5	36.0	27.8
1024	384	71.9	13.9	39.1	25.6
1024	432	75.2	13.3	42.0	23.8
1024	480	78.7	12.7	46.1	21.7
1024	528	82.0	12.2	49.0	20.4
1024	576	84.7	11.8	52.1	19.2
1024	624	89.3	11.2	54.9	18.2
1024	672	91.7	10.9	58.8	17.0
1024	720	95.2	10.5	62.1	16.1
1024	768	99.0	10.1	65.8	15.2

With Trigger ON, Packet Size = 3072, Shutter = 182 (33.1 ms), and video mode = YUV4:2:2

Image Width	Image Height	Frequency of trigger (Hz)	Maximum frequency of an external trigger shutter that can be input
1024	48	30.0	<div style="display: flex; align-items: center;"> <div style="border-left: 1px solid black; border-right: 1px solid black; border-bottom: 1px solid black; width: 20px; height: 100%; margin-right: 5px;"></div> <div> <p>Frame rates are affected by exposure time.</p> </div> </div>
1024	96	30.0	
1024	144	30.0	
1024	192	30.0	
1024	240	30.0	
1024	288	30.0	
1024	336	27.7	
1024	384	25.3	
1024	432	23.3	
1024	480	21.6	
1024	528	20.1	
1024	576	18.8	
1024	624	17.7	
1024	672	16.7	
1024	720	15.9	
1024	768	15.0	

DFW-SX910

With Trigger OFF, Packet Size = 2560, and video mode = YUV4:2:2

Image Width	Image Height	Shutter=182 (33.1 ms)		Shutter=3 (9 μ s)	
		Frame time (ms)	Frame rate (fps)	Frame time (ms)	Frame rate (fps)
1280	60	65.8	15.2	34.0	29.4
1280	120	71.9	13.9	39.1	25.6
1280	180	78.1	12.8	45.0	22.2
1280	240	84.0	11.9	50.0	20.0
1280	300	89.3	11.2	55.9	17.9
1280	360	95.2	10.5	62.1	16.1
1280	420	100.0	10.0	67.1	14.9
1280	480	106.4	9.4	73.0	13.7
1280	540	112.4	8.9	78.7	12.7
1280	600	116.3	8.6	84.0	11.9
1280	660	123.5	8.1	90.1	11.1
1280	720	128.2	7.8	96.2	10.4
1280	780	133.3	7.5	101.0	9.9
1280	840	140.8	7.1	106.4	9.4
1280	900	144.9	6.9	227.3 ^{*1}	4.4 ^{*1}
1280	960	151.5	6.6	238.1 ^{*2}	4.2 ^{*2}

*1 At this setting, amount of data output from the camera exceeds the 1394 bus bandwidth limitation. Thus, the frame rate reduces in half. Set the Shutter value to 22 (484 μ s) or larger.

*2 Set the Shutter value to 49 (2.4 ms) or larger.

With Trigger ON, Packet Size = 2560, Shutter = 182 (33.12 ms), and video mode = YUV4:2:2

Image Width	Image Height	Frequency of trigger (Hz)
1280	60	30.0
1280	120	25.2
1280	180	22.1
1280	240	19.5
1280	300	17.6
1280	360	16.0
1280	420	14.6
1280	480	13.5
1280	540	12.5
1280	600	11.7
1280	660	10.9
1280	720	10.3
1280	780	9.7
1280	840	9.2
1280	900	8.8
1280	960	8.4

Maximum frequency of an external trigger shutter that can be input

CCD Pixel Location (Top View)

DFW-SX910

Total number of pixels: 1434 (H) × 1050 (V)

Number of effective pixels: 1392 (H) × 1040 (V)

Number of output pixels: 1280 (H) × 960 (V) (Max.)

Size of unit cell: 4.65 μm (H) × 4.65 μm (V)

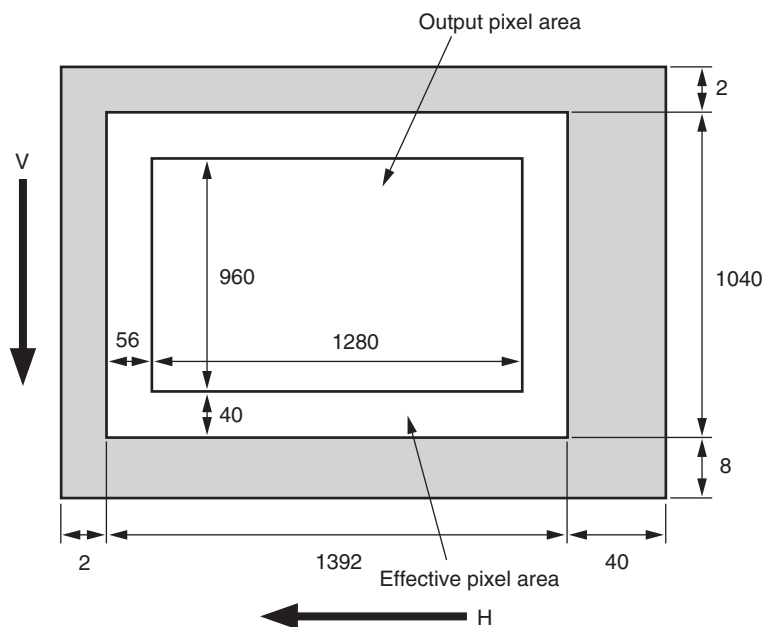

DFW-X710

Total number of pixels: 1077 (H) × 788 (V)

Number of effective pixels: 1034 (H) × 779 (V)

Number of output pixels: 1024 (H) × 768 (V)

Size of unit cell: 4.65 μm (H) × 4.65 μm (V)

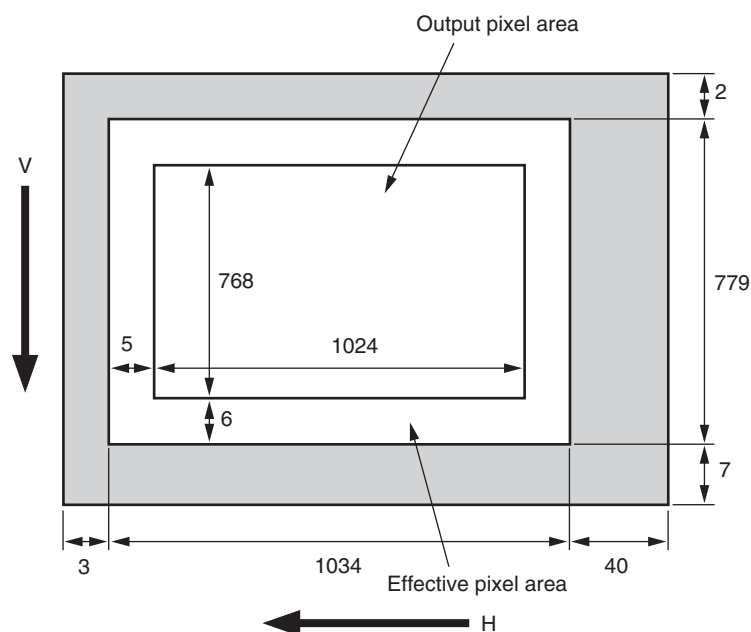

Spectral Sensitivity (Relative Response) Parameters

(Without lens and light source parameters.)

DFW-SX910/X710

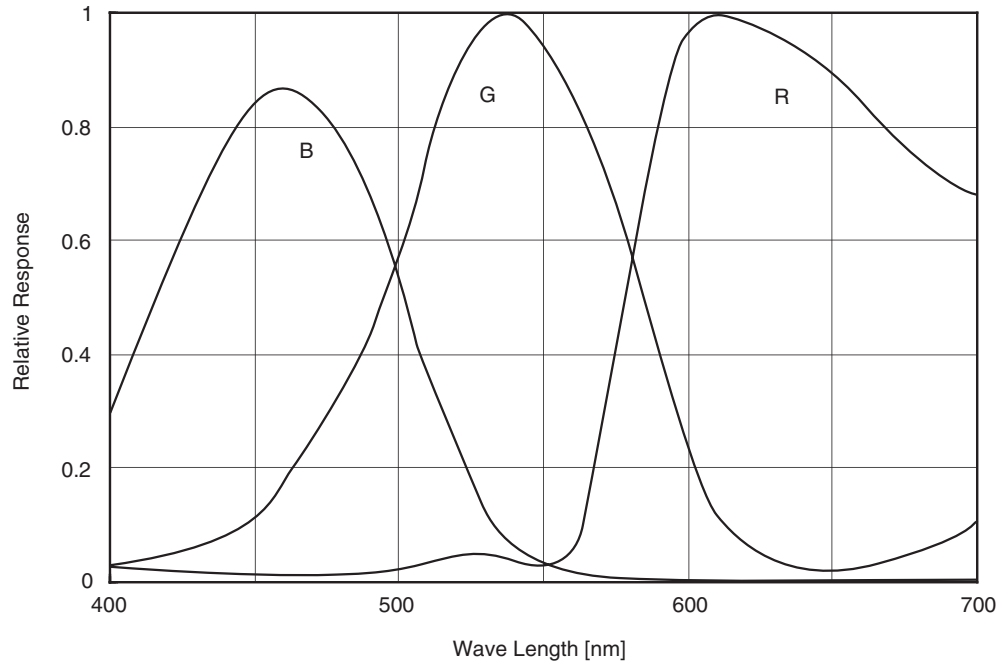

Dimensions

