

Features

- High Sensitivity and High Dynamic Performance Linear CCD
- Resolution:
 - 2048 Pixels with 14 μm Square Pixels
 - 6144 or 8192 Pixels with 7 μm Square Pixels
- 100% Aperture, Built-in Antiblooming, No Lag
- Camera Link[®] Data Format (Medium Configuration)
- High Data Rate:
 - 2048 Pixels: 120 Mpixels/s
 - 6144 and 8192 Pixels: 160 Mpixels/s
- Flexible and Easy to Operate Via Serial Control Lines (Camera Link)
 - Integration Time
 - Gain: 0 dB to 24 dB by Steps of 0.04 dB
 - Output Format: 8 or 10 Bits Data, 2 or 4 Taps
 - Offset (for Contrast Expansion)
 - Trigger Mode: Internal or External Trigger Modes
- Single Power Supply: 12 to 24V DC Provided on Hirose-6 Connector
- High Reliability – CE and FCC Compliant
- Available Lens Adapter (Lens Not Supplied)
- Flat-field Correction and Contrast Expansion

Description

This camera has been designed with three concepts in mind: compact design, accuracy and versatility. Atmel manages the entire manufacturing process, from the sensor to the camera. The result is a camera able to work in 8 or 10 bits, with dedicated electronics offering an excellent signal-to-noise ratio.

Applications

The high-speed, high-resolution performance and reliability of this camera make it well-suited for the most demanding industrial applications.

- OCR and barcode reading: postal and parcel sorting, document scanning
- Inspection and metrology: Flat Panel Displays, PCB, CD, DVD
- Web inspection: ceramic, printing, currency, textile, wood, paper
- The numerous programmable settings enable the user to implement the camera in many configurations: integration time, gain, offset, trigger mode, calibration (FFC and contrast expansion), output format...

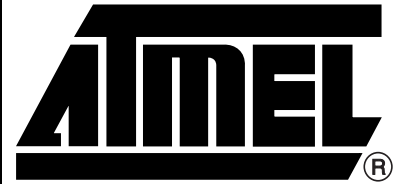

Camera Link[®]
Linescan
Camera
160 MHz

AViVA[®] M4 CL



5330C-IMAGE-07/05



1. Typical Performances

Table 1-1. Typical Performances of the 2K Pixel Camera

Parameter	Value		Unit
Sensor Characteristics			
Resolution	2048		pixels
Pixel size (square)	14		μm
Maximum Line rate	52		kHz
Peak data rate	4 x 30		MHz
Antiblooming	x 100		–
Radiometric Performances at Maximum Line Rate (at Gnom otherwise specified)			
Output format	8 or 10		bit
Spectral range	250 – 1100		nm
Linearity (10 to 90%)	1		% FSR ⁽⁵⁾
PRNU peak-to-peak at FSR/2 ⁽⁵⁾ (uncorrected)	6		%
FPN peak-to-peak ⁽¹⁾ (uncorrected)	2	18	LSB
Gain range (steps of 0.035 dB)	Gnom 0	Gmax 24	dB
Peak response ⁽¹⁾⁽²⁾ SEE ⁽²⁾	12.2 36	192 2.25	LSB/(nJ/cm ²) nJ/cm ²
NEE ⁽¹⁾⁽²⁾	56	35	pJ/cm ²
Dynamic range ⁽¹⁾	56	36	dB
Mechanical and Electrical Interface			
Size (w x h x l)	56 x 60 x 54		mm
Lens mount	No optical mount or F mount or T2 mount		–
Sensor alignment	$\Delta x, y = \pm 75$ $\Delta z = \pm 80$ $\Delta \theta_{x, y} = \pm 0.2$ $\Delta \text{tilt}_z = 0 - 50$		μm μm ° μm
Power supply	DC, single 11 to 25		V
Power dissipation	< 6.3		W
Maximum power-up current	0.65		A
Operating temperature ⁽³⁾	0 to 55 (non-condensing)		°C
Storage temperature	-40 to 85		°C
Camera setup time	5		s

- Notes:
1. Given for 8-bit resolution
 2. nJ/cm² measured on the sensor, at 3200K + BG38 2 mm thickness
 3. Front face temperature
 4. Measured response at nominal gain
 5. FSR as full scale range

Table 1-2. Typical Performances of the 6K and 8K Pixel Cameras

Parameter	Value		Unit
Sensor Characteristics			
Resolution	6K	6144	pixels
	8K	8192	
Pixel size (square)	7		µm
Maximum Line rate	6K	25.1	kHz
	8K	19	
Peak data rate	4 x 40		MHz
Antiblooming	x 100		–
Radiometric Performances at Maximum Line Rate (at Gnom otherwise specified)			
Output format	8 or 10		bit
Spectral range	250 – 1100		nm
Linearity (10 to 90%)	1		% FSR ⁽⁵⁾
PRNU peak-to-peak at FSR/2 ⁽⁵⁾ (uncorrected)	6		%
FPN peak-to-peak ⁽¹⁾ (uncorrected)	1	10	LSB
Gain range (steps of 0.035 dB)	Gnom 0	Gmax 24	dB
Peak response ⁽¹⁾⁽²⁾	3.25	52	LSB/(nJ/cm ²)
SEE ⁽²⁾	132	8.25	nJ/cm ²
NEE ⁽¹⁾⁽²⁾	200	125	pJ/cm ²
Dynamic range ⁽¹⁾	56	36	dB
Mechanical and Electrical Interface			
Size (w x h x l)	82 x 60 x 54		mm
Lens mount	No optical mount or M72 x 0.75		–
Sensor alignment	$\Delta x, y = \pm 75$ $\Delta z = \pm 80$ $\Delta \theta_{x, y} = \pm 0.2$ $\Delta \text{tilt}_z = 0 - 50$		µm µm ° µm
Power supply	DC, single 11 to 25V		V
Power dissipation	< 6.3		W
Maximum power-up current	0.65		A
Operating temperature ⁽³⁾	0 to 55 (non-condensing)		°C
Storage temperature	-40 to 85		°C
Camera setup time	5		s

- Notes:
1. Given for 8-bit resolution
 2. nJ/cm² measured on the sensor, at 3200K + BG38 2 mm thickness
 3. Front face temperature
 4. Measured response at nominal gain
 5. FSR as full scale range

Figure 1-1. Spectral Response

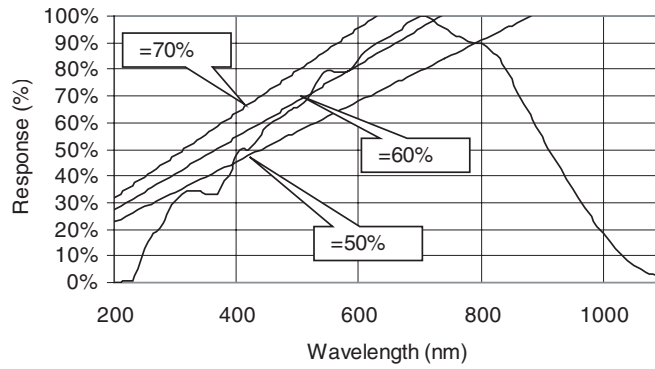

2. Description

2.1 CCD

The CCD uses 4 taps.

Figure 2-1. CCD Architecture

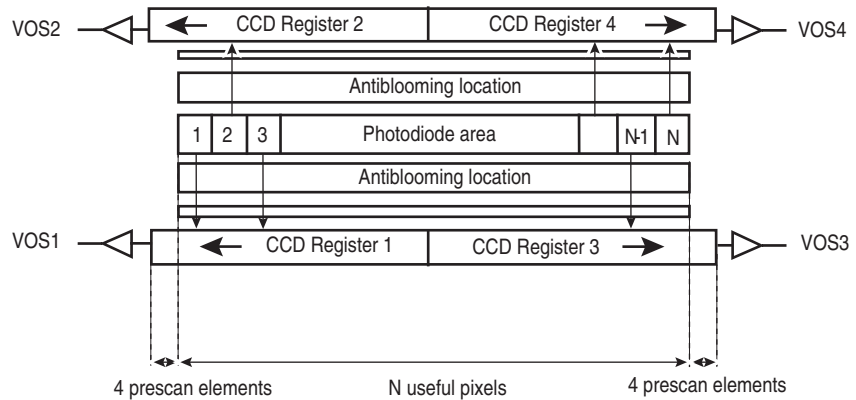

Note: The prescan pixels are not output from the camera.

2.2 Camera

Figure 2-2. Synoptic of Camera

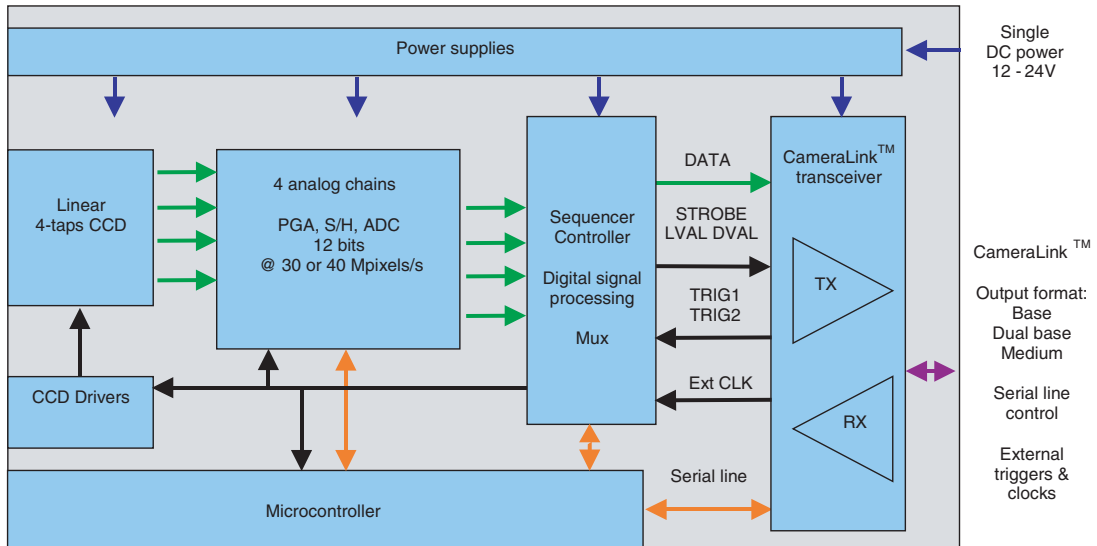
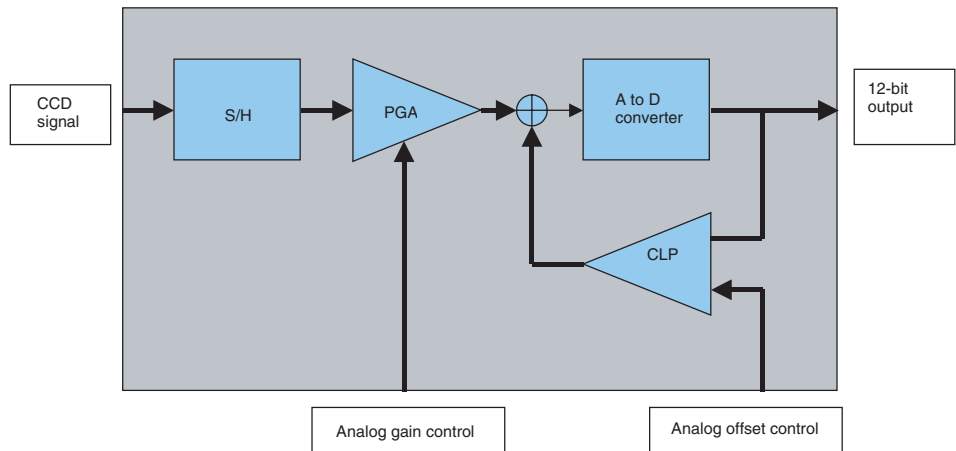
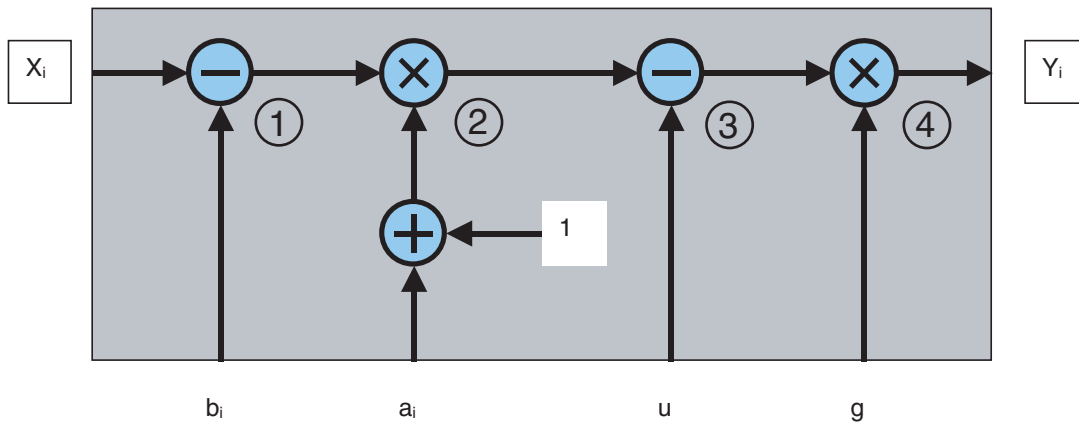

Figure 2-3. Analog Chain



- PGA: Programmable Gain Amplifier
- CLP: Clamp
- The applied Gain (dB) = applied value x 0.0351 (dB)
- The applied offset is offset on 12-bit data. When using only:
 - 10 bits, this value must be divided by 4
 - 8 bits, this value must be divided by 16
- Offset and gain values may be slightly adjusted to balance the four output gains and offset during factory tests.
- u: global offset for contrast expansion
- g: global gain for contrast expansion

Figure 2-4. Digital Signal Processing



FCC and contrast expansion can also be explained by the following graphic.

Figure 2-5. FCC and Contrast Expansion

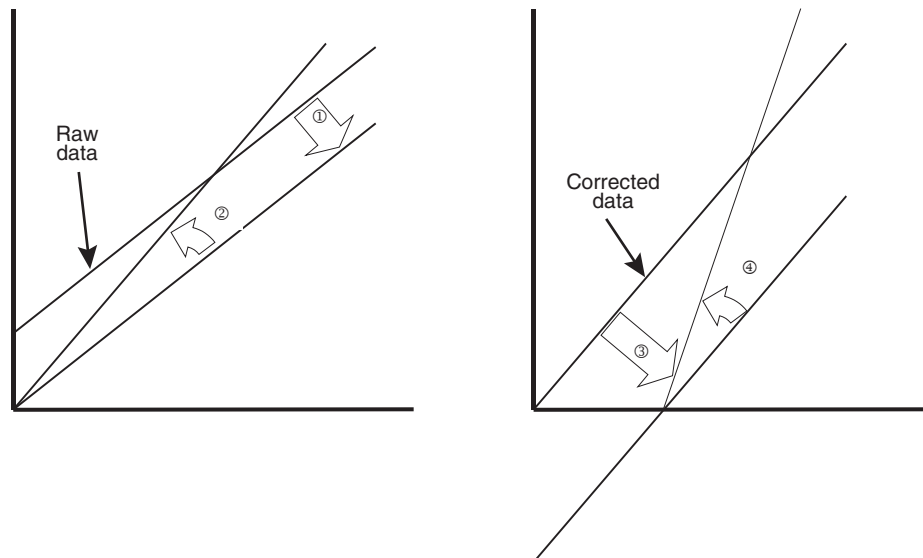

Flat field correction acts on each individual pixel:

- Step 1 is to correct the pixel dark and analog offset signal (b_i is subtracted from each X_i value).
- Step 2 is to correct the pixel gain (each value is multiplied by $a_i + 1$)

Contrast expansion acts on all pixels:

- Step 3 is to add the digital offset (offset u is subtracted from each value). If no contrast expansion is used, a negative value can be added to code the noise.
- Step 4 is to use the digital gain (each value is multiplied by g)

The AViVA[®] M4 cameras are based on four-tap linear CCDs. Therefore, four analog chains process pixels of the linear sensor. The analog chains perform the CCD output processing. It encompasses the dark level correction (dark pixel clamping), the gain (PGA) and offset correction and finally the analog to digital conversion on 12 bits (8- or 10-bit output).

Note: PGA stands for programmable gain amplifier.

- A single DC power voltage from 12V to 24V supplies the camera.
- The functional interface (data and control) is provided by the Camera Link interface.
- The camera uses the medium configuration of Camera Link standard.
- The camera can be used with an external trigger. The camera uses TRIG1 and TRIG2 signals in the different external trigger modes. The camera can be clocked externally, allowing system synchronization and/or multi-camera synchronization.

Note: FVAL = 0.

The camera configuration and settings are performed via a serial line. This interface is used to:

- Set the gain and offset
- Set the dynamic range and data rate
- Set the trigger mode: free running or external trigger modes
- Set the integration time: in free running and external trigger mode
- Write and read the FFC factors

2.3 Output Modes

Figure 2-6. Camera Link Medium or Dual Base Modes

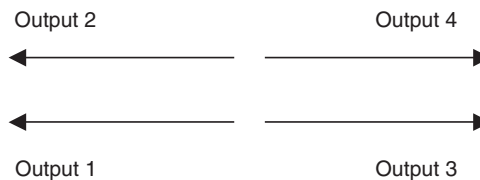
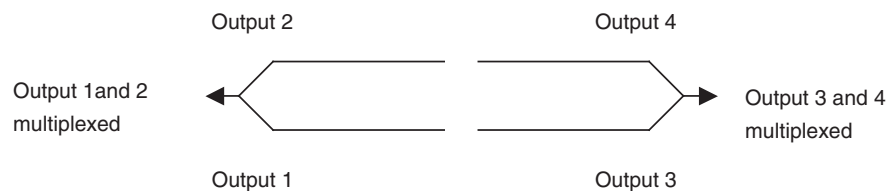

Figure 2-7. Camera Link Base Mode



- Note:
1. Output 1 and 2 multiplexed are output on Camera Link output 1
 2. Output 3 and 4 multiplexed are output on Camera Link output 2

3. Standard Conformity

The cameras have been tested using the following equipment:

- Shielded power supply cable.
- Two Camera Link data transfer cables ref. 14B26-SZLB-500-OLC (3M).

We recommend using this configuration to ensure compliance with the standards outlined below.

3.1 CE Conformity

AViiVA M4 cameras comply with the requirements of the EMC (European) directive 89/336/CEE (EN 50081-2, EN 61000-6-2).

3.2 FCC Conformity

AViiVA M4 cameras comply with Part 15 of the FCC rules, which states that:

Operation is subject to the following two conditions:

- This device may not cause harmful interference, and
- This device must accept any interference received, including interference that may cause undesired operation.

This equipment has been tested and found to comply with the limits for a Class A digital device, pursuant to part 15 of the FCC Rules. These limits are designed to provide reasonable protection against harmful interference when the equipment is operated in a commercial environment. This equipment generates, uses, and can radiate radio frequency energy and, if not installed and used in accordance with the instruction manual, may cause harmful interference to radio communications. Operation of this equipment in a residential area is likely to cause harmful interference in which case the user will be required to correct the interference at his own expense.

Warning: Changes or modifications to this unit not expressly approved by the party responsible for compliance could void the user's authority to operate this equipment.

4. Camera Commands and Controls

The AViVA M4 camera may be controlled through the Camera Link serial interface. After adjustments are made, all the parameters may be stored in an embedded E2PROM.

4.1 Syntax

The valid syntax is:

S=n(CR)

with:

- S: command identification. S is one to three characters long and key sensitive
- n: setting value
- (CR): carriage return

No spaces or tabs should be inserted between S, =, n and (CR).

Example of a valid command:

gal=300(CR)

This command sets the camera's channel 1 gain to position 300.

Example of non-valid commands:

gal = 300 (CR)	spaces
Gal=300 (CR)	G instead of g
gal=2000 (CR)	2000 is out of range

4.2 Command Processing

Each command received by the camera is processed.

If the command is valid:

- The setting is implemented
- The camera returns >OK (CR)

If the command is not valid:

- The camera returns ">"return_code (CR)

We recommend waiting for the camera to return ">OK" before sending a new command.

Table 4-1. Command Processing

Return Code	Meaning
>OK	OK
>128	Invalid command
>129	Communication failure
>130	Protocol failure
>131	Out-of-range parameter

Table 4-1. Command Processing

Return Code	Meaning
>132	Access failure
>133	Access denied (due to incorrect privilege)
>134	Initialization failure

4.3 Reading of Camera Information

When the camera receives " ! = 3 (CR) ", the camera returns its current settings. For example:

```

! = 3
res=0
+F=1
+p=1
ga1=0
ga2=0
ga3=0
ga4=0
oa1=70
oa2=70
oa3=70
oa4=70
ncv=0
gnu=0
int=100
per=0
out=0
syn=2
ouf=2
mod=0
cls=0
ccd=8192 (or 2048 or 6144)
>OK

```

4.4 List of Commands

4.4.1 Signal Processing Settings

Table 4-2. Analog Settings

Description	Command	Default Value	Range or Values	Functionalities
Channel 1 gain	ga1	0	0 to 700	Analog gain (dB) = G x 0.0351
Channel 2 gain	ga2	0	0 to 700	Analog gain (dB) = G x 0.0351
Channel 3 gain	ga3	0	0 to 700	Analog gain (dB) = G x 0.0351
Channel 4 gain	ga4	0	0 to 700	Analog gain (dB) = G x 0.0351
Channel 1 offset	oa1	70	0 to 255	Channel 1 analog offset adjustment
Channel 2 offset	oa2	70	0 to 255	Channel 2 analog offset adjustment
Channel 3 offset	oa3	70	0 to 255	Channel 3 analog offset adjustment
Channel 4 offset	oa4	70	0 to 255	Channel 4 analog offset adjustment

Table 4-3. Digital Settings

Description	Command	Default Value	Range or Values	Functionalities
Numerical contrast value	ncv	0	-4096 to +4095	Allows offset adjustments and contrast expansion
Numerical gain	gnu	0	0 to 255	Allows digital gain for contrast expansion Applied digital gain is 1+ value/8

Table 4-4. Camera Settings

Description	Command	Default Value	Range or Values	Functionalities
Restore settings	res	0	0	Factory settings
			1 to 4	Customer settings 1 to 4
Number of outputs	out	2	0	Four outputs in Camera Link dual base mode
			1	Two divergent outputs in Camera Link base mode
			2	Four outputs in Camera Link medium mode
Output format	ouf	2	1	Output on 10 bits
			2	Output on 8 bits
Clock source	cls	0	0	Internal clock
			1 ^(Note:)	External clock using rising edge
			2 ^(Note:)	External clock using falling edge
Integration time	int	200	1 to 32768	Integration time by 1 μs steps
Line period	per	0	0-32768	Line period by 1μs steps

Table 4-4. Camera Settings (Continued)

Description	Command	Default Value	Range or Values	Functionalities
Synchronization mode	syn	1	1	Free run mode with integration time set by serial line
			2	Trigger mode with integration time set by serial line
			3	ITC (Integration Time Control) with one signal
			4	ITC (Integration Time Control) with two signals
			5	External triggered readout
Output mode	mod	0	0	CCD signal output
			1	CCD signal output with digital corrections
			2	Test pattern

Note: Not available on the 2K

4.5 Test Pattern

The test pattern comprises 512 values that are repeated on each channel to complete the line.

Table 4-5. Test Pattern Values

Values 1 to 496	First Ramp		Second Ramp	
@	1	256	257	496
	From	To	From	To
12	0	255	3856	4095
10	0	63	964	1023
8	0	15	241	255

	Values 497 to 500				Values 501 to 504				Values 505 to 508				Values 509 to 512			
	Output				Output				Output				Output			
	1	2	3	4	1	2	3	4	1	2	3	4	1	2	3	4
12	320	384	448	512	576	640	704	768	1088	1152	1216	1280	2112	2176	2240	2304
10	80	96	112	128	144	160	176	192	272	288	304	320	528	544	560	576
8	20	24	28	32	36	40	44	48	68	72	76	80	132	136	140	144

The multiplexed 8-bit output is illustrated as follows for an 8K camera.

Figure 4-1. Multiplexed Output for an 8K Camera

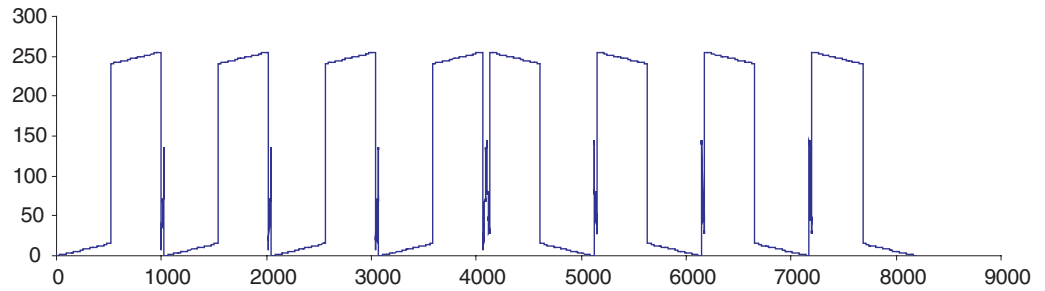
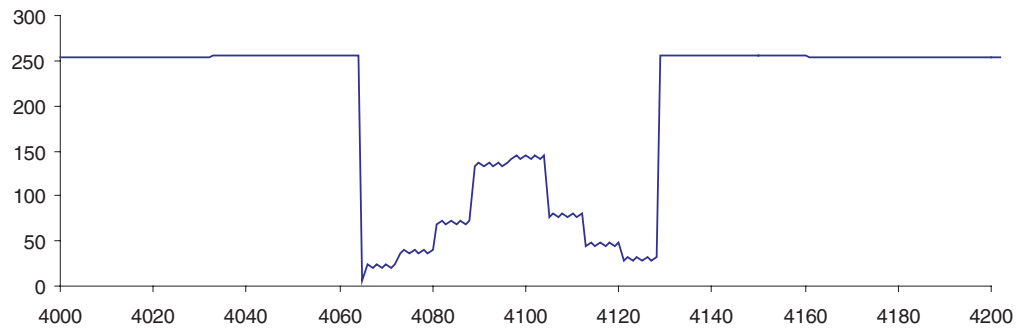

Figure 4-2. Illustration of Image Center



4.6 Status and ID Readout

Table 4-6.

Description	Command	Range or Values	Functionalities
Camera status	!	0	Camera ID readout
		1	Customer ID readout
		3	The camera sends all its settings see ^(4.3)
		4	Camera status readout
		8	Software version readout
Customer identification storage	cid		50 ASCII character set by customer

4.6.1 Camera ID

!=0

A character string stored in E2PROM gives the product model, its version and its serial number.

Example: **AT71XM4CL2014-BA1-1452-0243A0398-00** stands for:

- Camera part number: AT71XM4CL2014- (1 to 18 characters)
- Options: BA1 (3 characters)
- Lot number: 1452 (1 to 10 characters)
- Camera’s serial number: 0243A0398 (9 characters)
- Software compatibility: 00 (2 characters)

Please note that Atmel may change this ID structure without notice.

4.6.2 Customer ID

!=1 & cid=xxx

The customer identification is a character string (50 characters maximum).

- It is set and stored in E2PROM by sending **cid=xx..xx**
- It is read by sending **=1(CR)**
- The customer identification is stored in EEPROM

4.6.3 Camera Status

!=4

The camera will respond by a decimal number. This will help to identify if the external signals needed are applied to the camera or not.

Table 4-7. Camera Status

Status Bts	Use	Value	Meaning
15-4	Not used	0	
3	PLL status	1	"OK"
		0	PLL not locked
2	External clock status	1	External clock detected or camera set in internal clock mode.
		0	No external clock detected when camera is set in external clock mode.
1	Trig 2 status	1	Trig 2 signal detected (rising or falling edge) or Camera set in any other mode than "Integration Time Control mode with two signals".
		0	No Trig 2 signal detected and the Camera set in "ITC 2 x Trig" mode.
0	Trig 1 status	1	Trig 1 signal detected (rising or falling edge) or Camera set in Free Run mode
		0	No Trig 1 signal detected and the Camera set in any Trig mode (other mode than Free Run).

After changing the trigger mode or after status register readout, the status register is set to 0.

- If there is no problem (camera OK and all needed synchronization or clock signals are provided to the camera) the status register readout should be "15".
- If the status register is at 15 the LED is lighten continuously.
- If the status register is lower than 15 the LED is blinking slowly. (example if external triggers are not available or too slow)
- If the camera is not able to load its firmware, the LED is blinking fast.

4.6.4 Storage Settings

The maximum number of write cycles allowed for the E2PROM is 100,000. Therefore, the configuration must not be stored more than 100,000 times.

Table 4-8. Configuration of Storage Settings

Description	Command	Default Value	Range or Values	Functionalities
Saving configuration	sav		1	Storage of settings N° 1
			2	Storage of settings N° 2
			3	Storage of settings N° 3
			4	Storage of settings N° 4

5. Flat Field Correction (FFC)

By applying an $Ax + B$ formula per pixel, flat field correction enables correction of:

- Dark signal non-uniformity (DSNU)
- Fixed pattern noise

FPN includes these two parameters.

- CCD photo-response non uniformity (PRNU)
- Lens vignetting
- Light source non-uniformity

PRNU includes these three parameters.

In AViVA cameras, the FFC is completed by a contrast expansion function.

Note: Note that use of digital multiplications with results on integer numbers may cause missing codes. The AViVA M4 includes a flat field correction function. There are two methods for performing the FFC calibration:

1. Manually: this method manages all the parameters globally for best results. One can choose the number of acquired lines to be averaged and can also modify the parameters for some chosen pixels to compensate, for example, an incorrect calibration calculation due to an incorrect reference "white paper".
2. Semi-automatically: this method consists in acquiring the image on a computer and making the calculations on CommCam software.

Whichever method is used, it is always possible to modify some factors manually.

It is always necessary to save the factors after calibration otherwise they will be lost once the camera is turned off.

Before starting a calibration, the camera must be configured and set-up as it will be in the final application. Any change in the settings (frequency, analog gain, etc...) or operating condition (temperature) will require a new calibration.

The "analog offset" values must be superior to zero for good FPN calibration. The default value (128 LSB for the 12-bit version, 32 for 10 bits...) is advised.

The correction factors may be computed from images taken without FFC and without contrast expansion but with the analog gain selected. To remove noise, the acquired images must be averaged otherwise the FFC will introduce a fixed pattern noise.

An average on the N line reduces the noise value by a factor \sqrt{N} .

5.1 Algorithm

$$Y_i = \{ [(X_i - b_i) \times (1 + a_i)] - u \} \times g$$

With:

Y_i	Corrected pixel value
X_i	Raw pixel value output from the A to D conversion. This value includes the signal, the dark signal and the analog offset setting
b_i	FPN coefficient: offset correction of pixel i. On 12-bit images, values are computed on 9 bits during the calibration procedure
a_i	PRNU coefficient: gain correction applied to pixel i after addition to 1. On 12-bit images, values computed on 14 bits are comprised between 0 and 1 ($a_i = N/16384$)
u	User programmed offset subtracted from each pixel value. It is comprised between -4096 and +4095. This offset will enable contrast expansion and/or noise representation when the user wants a "linear" data representation
g	User programmed gain applied to all pixels to perform a contrast expansion. Adjustable value comprised between x1 and x32 (30 dB), 8-bit precision: $g = 1 + N/8$ with N being the input number (0 to 255)

Note: All calculations are made on at least 14 bits and the data is then output on the needed number of bits (8 or 10).

5.2 Data Acquisition Calibration

5.2.1 FPN Data

To acquire this data, there must not be any light falling on the camera. The lens must be closed, covered or the light turned off.

The number of lines to be averaged depends on the image noise that in turn depends on:

- The gain
- The integration time
- The temperature of the CCD

For each correction factor the final value must have a lower noise than the system is able to detect.

The analog offset of each output must be adjusted first to obtain a valid value for each pixel (no zero value allowed).

The FPN factor, coded on 9 bits for each pixel, is the offset value for a 12-bit output data (the LSB of the FPN factor corresponds to the LSB of the 12-bit data). So when using the camera with only:

- 8 bits output, the value must be multiplied by 16
- 10 bits output, the value must be multiplied by 4

Example:

- Sending 256 will correct an offset of 16 on an 8-bit pixel
- Sending 342 will correct an offset of 85 on a 10-bit pixel

5.2.2 PRNU Data

To acquire this data, light must fall on the camera. The quality of the calibration will depend on the reference quality.

To obtain the best signal-to-noise ratio, the signal value must be as close as possible to the camera saturation with the used gain. One must take care to avoid any saturation on the image.

The number of lines to be averaged depends on the camera noise that in turn depends on:

- The gain
- The light stability

Any shot noise must be removed so as not to introduce any fixed pattern noise.

The maximum correction factor is x2. The highest pixel correction value must be set to x1 and the others between x1 and x2.

The values comprised between 1 and 2 must be processed and the FPN correction must be performed first.

Example:

- Sending 0 will apply a gain of 1 to this pixel
- Sending 8192 will apply a gain of 1.5 to this pixel

5.3 Data Storage

The AViVA M4 camera allows:

- 4 storage "banks" to store the PRNU data
- 4 storage "banks" to store the FPN data

The user must select the required banks among these 8 banks. At power-on, the camera will automatically use the 2 most recently used banks.

All the banks are empty upon delivery of the camera.

The serial line may be used to write or read the volatile memory content. Special commands may be used to store the data in non-volatile memories.

5.4 FFC Serial Control List

Table 5-1. FCC Serial Control Settings

Description	Command	Default Value	Range or Values	Functionalities
Write FPN	wfp			Writes the specified amount of FPN data in the volatile memory . If needed a CRC may be used at the end
Read FPN	rfp			Reads the specified amount of FPN data from the volatile memory . CRC ends the return message
Write PRNU	wpr			Writes the specified amount of PRNU data in the volatile memory . If needed a CRC may be used at the end
Read PRNU	rpr			Reads the specified amount of PRNU data from the volatile memory . CRC ends the return message
FPN recall	+f		1 to 4	Fills the volatile memory with the specified non-volatile FPN bank
FPN storage	-f		1 to 4	Fills the specified non-volatile FPN bank with the volatile memory content
PRNU recall	+p		1 to 4	Fills the volatile memory with the specified non-volatile PRNU bank
PRNU storage	-p		1 to 4	Fills the specified non-volatile PRNU bank with the volatile memory content.

5.5 FFC Serial Control Example

Commands are composed of:

wfp =<addr> <size> <value> ... <value> [crc16]

rfp =<addr> <size> [with_crc]

wpr =<addr> <size> <value> ... <value> [crc16]

rpr =<addr> <size> [with_crc]

With:

- <addr> = decimal address of the first data (must be between 1 and the CCD size)
- <size> = amount of data sent in this command (must be between 1 and 5)
(addr + size -1) must be less than the CCD size
- <value> = data decimal value on N bits
 - For the offset: N between 0 and 511
 - For the gain: N between 0 and 16383 = (pixel gain - 1) x 16384. The pixel gain is x1 to x2
 - [crc16] = (optional) result of an “exclusive” or initialized at 0 on each of the 16 bits
- [with_crc] = flag use or non use of the CRC:
 - Nothing or 0 = no CRC
 - 1 = with CRC

wfp =101 5 125 132 140 120 128 will write:

- 125 at address 101
- 132 at address 102
- ...
- 128 at address 105
- No CRC is sent

Sending the 8192 PRNU correction data will take about two and a half minutes.

6. Timing

6.1 Synchronization Modes

Five different modes may be used.

- The TRIG1 and TRIG2 signals may be used to trigger an external event and control the integration time.
- The Master clock is either external or internal.
- The readout period starts automatically after the integration time period.
- The readout time depends on the number of pixels (2048/N, 6144/N or 8192/N).
N = number of camera outputs used (4 in normal mode, 2 in multiplexed mode).
- The readout of useful pixels occurs during LVAL high state.

6.1.1 Free Run Mode

Synchronization Mode 1

Serial order: syn = 1.

The new line starts automatically and immediately after the previous one. If the programmed line period (per) is lower than the Lp min then the line period is set to the minimum line period. If the programmed integration time (int) is greater than the programmed line period (per) then the line period is set to integration time. The read-out time depends on pixel number and pixel rate.

Figure 6-1. Free-run Mode Timing Diagram

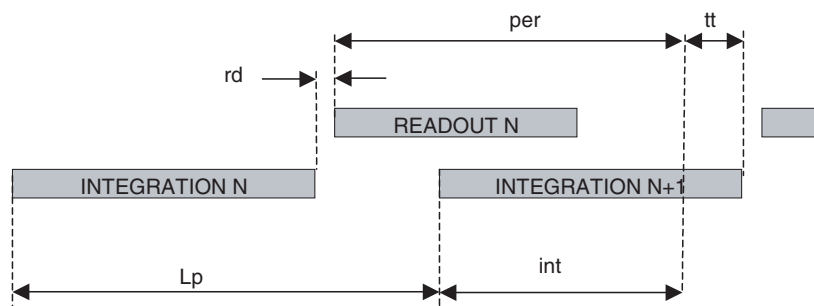

6.1.2 Triggered Mode

Synchronization Mode 2

Serial order: $syn = 2$.

The integration period starts immediately after the rising edge of the TRIG1 input signal. The integration time is set through the serial line. This integration period is immediately followed by a readout period. The readout time depends on the number of pixels and the pixel rate.

Figure 6-2. Triggered Mode Timing Diagram

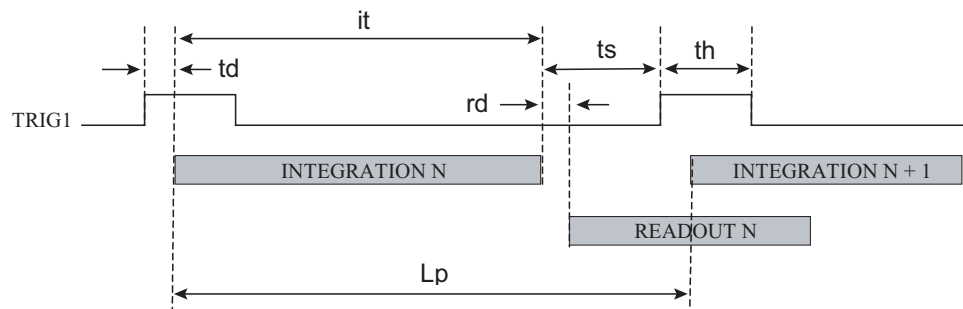

6.1.3 Integration Time Control Mode with One Signal

Synchronization Mode 3

Serial order: $syn = 3$

The integration period starts immediately after the falling edge of TRIG1 and stops immediately after the rising edge of TRIG1. This integration period is immediately followed by a readout period. The readout time depends on the number of pixels and the pixel rate. The pixels are reset while TRIG1 is high.

Figure 6-3. ITC Mode with One Signal Timing Diagram

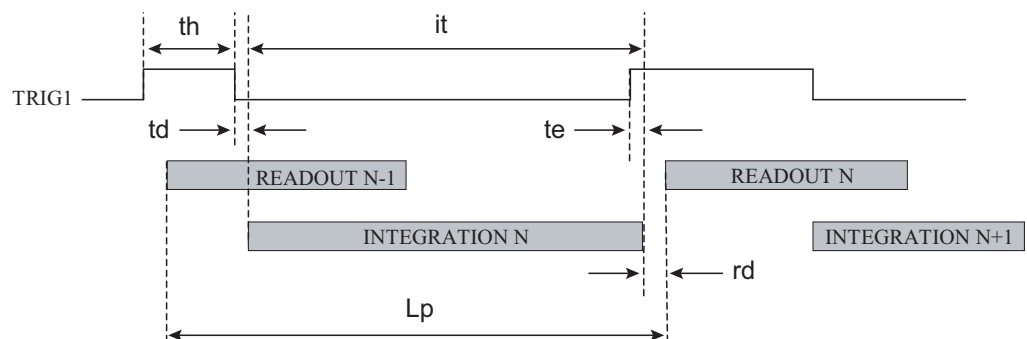

6.1.4 Integration Time Control Mode with Two Signals

Synchronization Mode 4

Serial order: syn = 4

The rising edge of TRIG2 starts the integration period. The rising edge of TRIG1 stops the integration period and starts the readout period. The pixels are reset between the rising edge of TRIG1 and the rising edge of TRIG2.

Figure 6-4. ITC Mode with Two Signals Timing Diagram

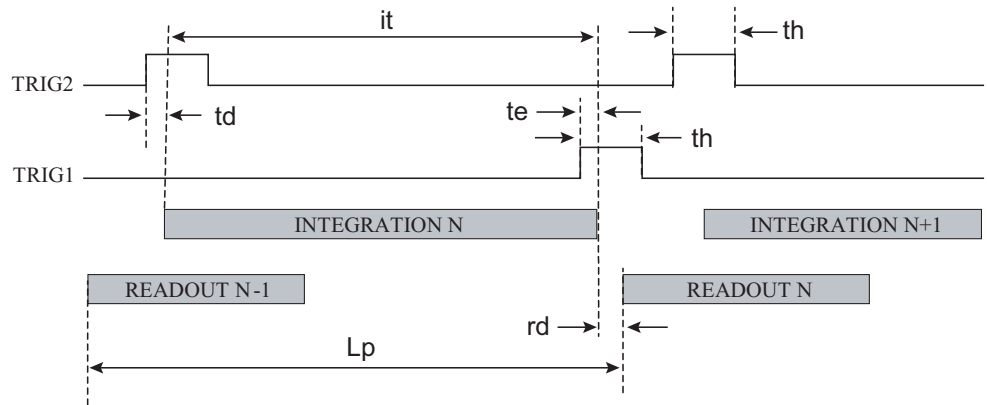

6.1.5 Triggered Readout Mode

Synchronization Mode 5

Serial order: syn = 5.

The readout period and the next integration period start immediately after the rising edge of the TRIG1 input signal.

Figure 6-5. Triggered Readout Mode Timing Diagram

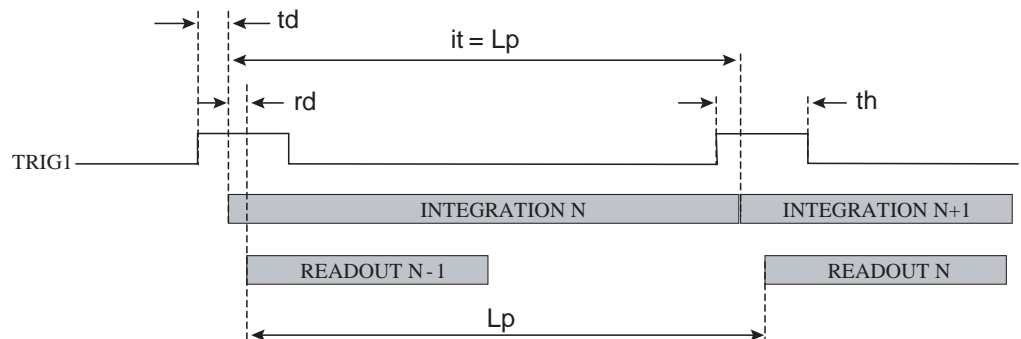

6.2 Timing Specifications

Table 6-1. Timing Definitions

Label	Description
td	Trigger to start of integration delay
th	External trigger hold time (minimum pulse high duration)
it	Integration time duration
Lp	Line period
te	End of integration trigger to real end of integration time delay
ts	End of integration time to start of integration time delay
rd	End of integration period to readout delay
rp	Readout duration
tt	End of readout cycle to end of integration time

Table 6-2. Timing Specifications

Label	Synchronization Modes	Units	CCD	Output Modes	
				4 Outputs	2 Outputs
it min	1, 5	MCP	2k	490	1051
			6k	1514	3099
			8k	2026	4123
	2	MCP	2k	508	1120
			6k	1532	3168
			8k	2044	4192
3, 4	μs	All	1	1	
rp	All	MCP	2k	512	1024
			6k	1536	3072
			8k	2048	4096
td	2, 3, 4	MCP	All	88	88
	5	MCP	All	63	106
th min	2, 3, 4, 5	MCP	All	>2	>5
tr	3, 4	MCP	All	63	106
ts	2	MCP	All	70	120
rd	All	MCP	All	27	52
Lp min	All	μs	2k	19.7	37
			6k	40.5	79.2
			8k	53.3	104.8
tt	1	ns MCP	All	400 ns + 40 MCP	400 ns + 80 MCP

- Notes: 1. Times are given in seconds or in number of master clock periods (MCP)
 2. MCP is 33 ns when master clock frequency is 30 MHz and 25 ns when master clock frequency is 40 MHz

6.3 Output Data Timing

Table 6-3.

tt	1	nsMCP	All	400 ns + 40 MCP	400 ns + 80 MCP

Figure 6-6. Timing Diagram at Camera Link Device Input

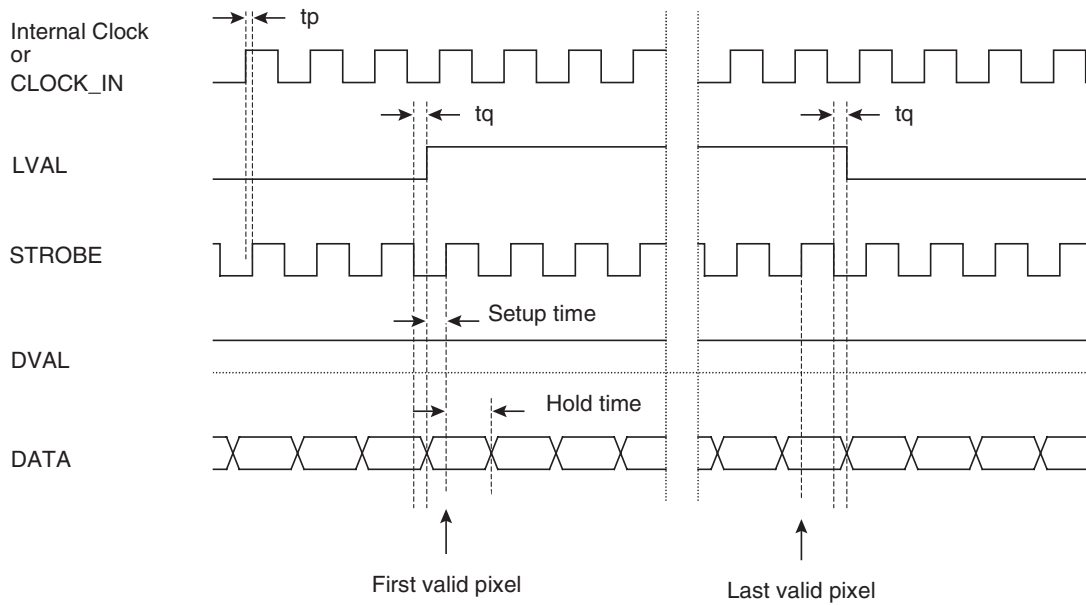

7. Electrical Interface

7.1 Power Supply

We recommend that you insert a 1 amp fuse between the power supply and the camera. The voltage ripple of the power supply should be below ± 50 mVpp at BW = 50 MHz for full camera performance.

Table 7-1. Power Supply

Signal Name	I/O	Type	Description
PWR	P	–	DC power input: +12 to +24V
GND	P	–	Electrical and mechanical ground

Note: I = input, O = output, IO = bi-directional signal, P = power/ground, NC = not connected

7.2 Command and Control

The Camera Link interface provides four LVDS signals dedicated to camera control (CC1 to CC4). On the AViVA, three of them are used to synchronize the camera with external events.

1. FVAL, as defined in the Camera Link standard, is not used. FVAL is permanently tied to the 0 (low) level.
2. CC3 is not used

Table 7-2. Signal Definitions

Signal Name	I/O ⁽²⁾	Type	Description
TRIG1	I	EIA-644	CC1 – synchronization input ⁽¹⁾
TRIG2	I	EIA-644	CC2 – start Integration period in dual synchro mode ⁽¹⁾
CLOCK_IN	I	EIA-644	CC4 – external clock for (multi-) camera synchronization ⁽¹⁾

Notes: 1. Refer to ["Synchronization Modes" on page 19](#).
 2. I = input, O = output, IO = bi-directional signal, P = power/ground, NC = not connected

7.3 Video Data

Data and enable signals are provided on the Camera Link interfaces.

1. FVAL, as defined in the Camera Link standard, is not used. FVAL is permanently tied to 0 (low) level.
2. DVAL, as defined in the Camera Link standard, when used is active at high level.

Table 7-3. Video Data

Signal Name	I/O ⁽²⁾	Type	Description
OUT1-D[9-0]	O	EIA-644	Out 1 pixel data, OUT1-0 = LSB, OUT1-9 = MSB ⁽¹⁾
OUT2-D[9-0]	O	EIA-644	Out 2 pixel data, OUT2-0 = LSB, OUT2-9 = MSB ⁽¹⁾
OUT3-D[9-0]	O	EIA-644	Out 3 pixel data, OUT3-0 = LSB, OUT3-9 = MSB ⁽¹⁾
OUT4-D[9-0]	O	EIA-644	Out 4 pixel data, OUT4-0 = LSB, OUT4-9 = MSB ⁽¹⁾
STROBE	O	EIA-644	Output data clock, data valid on the rising edge ⁽¹⁾
LVAL	O	EIA-644	Line valid or line enable, active high signal ⁽¹⁾
DVAL	O	EIA-644	Data valid, active high signal

Notes: 1. Refer to ["Output Data Timing" on page 23](#)
 2. I = input, O = output, IO = bi-directional signal, P = power/ground, NC = not connected

7.4 Serial Communication

The Camera Link interface provides two LVDS signal pairs for communication between the camera and the frame grabber. This is an asynchronous serial communication based on the RS-232 protocol.

The configuration of the serial line is:

- Full duplex/without handshaking

- 9600 bauds, 8-bit data, no parity, 1 stop bit

Table 7-4. Signal Definition

Signal Name	I/O	Type	Description
SerTFG	O	EIA-644	Differential pair for serial communication to the frame grabber
SerTC	I	EIA-644	Differential pair for serial communication from the frame grabber

The camera is delivered with:

- Software dedicated to camera control
- .dll and .h files to allow camera control in a customer development software

8. Connector Description

All connectors are on the rear panel. Better results are obtained by using shielded cables (foil and braid).

8.1 Camera Link Connector

Standard Camera Link cables should be used to ensure full electrical compatibility.

Camera connector type: 2 x MDR-26 (female) ref. 10226-2210VE

Cable connector type: a standard Camera Link cable should be used (ex. 3M™ – 14B26-SZLB-x00-OLC)

Table 8-1. Camera Link Connector

Signal	Pin	Signal	Pin
GND	1	GND	14
X0-	2	X0+	15
X1-	3	X1+	16
X2-	4	X2+	17
Xclk-	5	Xclk+	18
X3-	6	X3+	19
SerTC+	7	SerTC-	20
SerTFG-	8	SerTFG+	21
CC1-	9	CC1+	22
CC2+	10	CC2-	23
CC3-	11	CC3+	24
CC4+	12	CC4-	25
GND	13	GND	26

8.1.1 Bit Assignment

The bit assignment is compliant with Camera Link specifications in the **Medium Configuration with two cables** (see the Camera Link documentation from the Automated Imaging Association).

8.2 Power Supply

Camera connector type: Hirose HR10A-7R-6PB (male)

Cable connector type: Hirose HR10A-7P-6S (female), one connector is delivered with each camera.

Table 8-2. Power Connector J01

Signal	Pin	Signal	Pin
PWR	1	GND	4
PWR	2	GND	5
PWR	3	GND	6

Figure 8-1. Receptacle Viewed from the Rear of the Camera

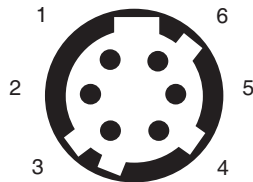

9. Ordering Codes

Table 9-1. Cameras

Item	Part Number
AVIIVA M4 Camera Link 2048 pixels 14 μm	AT71-M4CL2014-BA1
AVIIVA M4 Camera Link 6144 pixels 7 μm	AT71-M4CL6007-BA1
AVIIVA M4 Camera Link 8192 pixels 7 μm	AT71-M4CL8007-BA1

Note: The cameras are delivered with a power supply connector.

Table 9-2. Optical Mount

Item	Part Number
F Mount for Aviiva M4 2k or 6k	AT71-AVIIVAX4-F
T2 Mount for Aviiva M4 2k or 6k	AT71-AVIIVAX4-T2
M72 x 0.75 Mount for Aviiva M4 8k	AT71-AVIIVAX4-M72

Note: The cameras are delivered without an optical mount.

Table 9-3. BG38 Filters

Item	Part Number
Kit BG38 for 2k and 6k	AT71ABG38AVIVX4-6K
Kit BG38 for 8k	AT71ABG38AVIVX4-8K

Note: Filters are held by an optical mount

Table 9-4. Accessories

Item	Part Number
2 Camera Link cables (5 meters long)	AT71KAVIIVA-X4-CL
Optional heatsink	Please contact factory

10. Mechanical Characteristics

10.1 Weight

The camera's typical weight (without lens) is 500g (TBC).

10.2 Dimensions

Figure 10-1. 2k

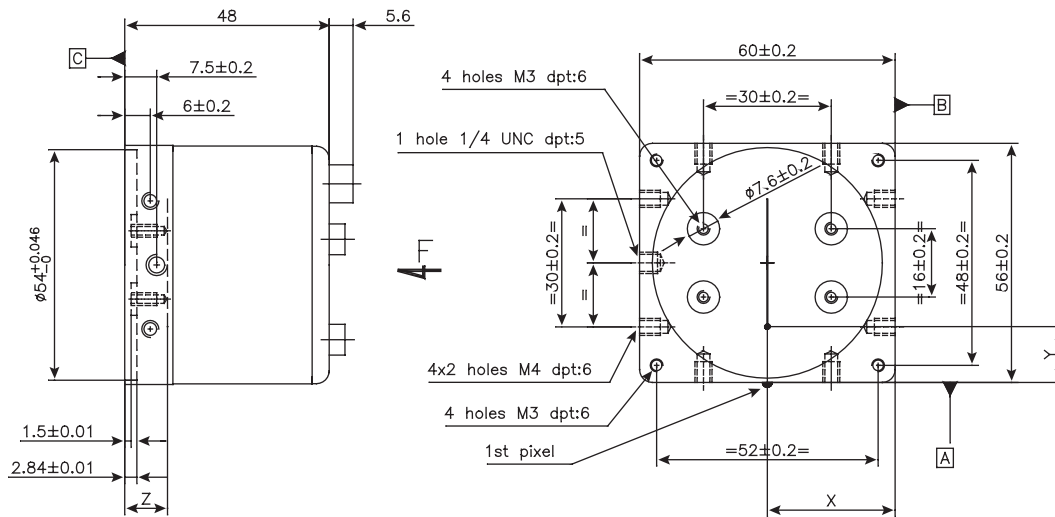
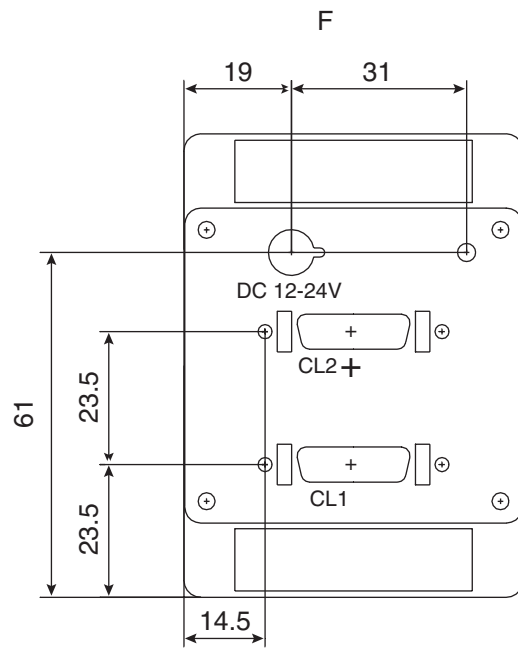

Table 10-1. X, Y, Z Dimensions

	2K	6K	8K
X	30 mm	30 mm	30 mm
Y	13.66 mm	19.5 mm	12.3 mm
Z	11.3 mm	11.3 mm	11.3 mm

Figure 10-4. Rear Face



Note: The 2k rear face does not have the two heat sinks.



Atmel Corporation

2325 Orchard Parkway
San Jose, CA 95131, USA
Tel: 1(408) 441-0311
Fax: 1(408) 487-2600

Regional Headquarters

Europe

Atmel Sarl
Route des Arsenalux 41
Case Postale 80
CH-1705 Fribourg
Switzerland
Tel: (41) 26-426-5555
Fax: (41) 26-426-5500

Asia

Room 1219
Chinachem Golden Plaza
77 Mody Road Tsimshatsui
East Kowloon
Hong Kong
Tel: (852) 2721-9778
Fax: (852) 2722-1369

Japan

9F, Tonetsu Shinkawa Bldg.
1-24-8 Shinkawa
Chuo-ku, Tokyo 104-0033
Japan
Tel: (81) 3-3523-3551
Fax: (81) 3-3523-7581

Atmel Operations

Memory

2325 Orchard Parkway
San Jose, CA 95131, USA
Tel: 1(408) 441-0311
Fax: 1(408) 436-4314

Microcontrollers

2325 Orchard Parkway
San Jose, CA 95131, USA
Tel: 1(408) 441-0311
Fax: 1(408) 436-4314

La Chantrerie
BP 70602
44306 Nantes Cedex 3, France
Tel: (33) 2-40-18-18-18
Fax: (33) 2-40-18-19-60

ASIC/ASSP/Smart Cards

Zone Industrielle
13106 Rousset Cedex, France
Tel: (33) 4-42-53-60-00
Fax: (33) 4-42-53-60-01

1150 East Cheyenne Mtn. Blvd.
Colorado Springs, CO 80906, USA
Tel: 1(719) 576-3300
Fax: 1(719) 540-1759

Scottish Enterprise Technology Park
Maxwell Building
East Kilbride G75 0QR, Scotland
Tel: (44) 1355-803-000
Fax: (44) 1355-242-743

RF/Automotive

Theresienstrasse 2
Postfach 3535
74025 Heilbronn, Germany
Tel: (49) 71-31-67-0
Fax: (49) 71-31-67-2340

1150 East Cheyenne Mtn. Blvd.
Colorado Springs, CO 80906, USA
Tel: 1(719) 576-3300
Fax: 1(719) 540-1759

Biometrics/Imaging/Hi-Rel MPU/ High Speed Converters/RF Datacom

Avenue de Rochepleine
BP 123
38521 Saint-Egreve Cedex, France
Tel: (33) 4-76-58-30-00
Fax: (33) 4-76-58-34-80

Literature Requests

www.atmel.com/literature

Disclaimer: The information in this document is provided in connection with Atmel products. No license, express or implied, by estoppel or otherwise, to any intellectual property right is granted by this document or in connection with the sale of Atmel products. **EXCEPT AS SET FORTH IN ATMEL'S TERMS AND CONDITIONS OF SALE LOCATED ON ATMEL'S WEB SITE, ATMEL ASSUMES NO LIABILITY WHATSOEVER AND DISCLAIMS ANY EXPRESS, IMPLIED OR STATUTORY WARRANTY RELATING TO ITS PRODUCTS INCLUDING, BUT NOT LIMITED TO, THE IMPLIED WARRANTY OF MERCHANTABILITY, FITNESS FOR A PARTICULAR PURPOSE, OR NON-INFRINGEMENT. IN NO EVENT SHALL ATMEL BE LIABLE FOR ANY DIRECT, INDIRECT, CONSEQUENTIAL, PUNITIVE, SPECIAL OR INCIDENTAL DAMAGES (INCLUDING, WITHOUT LIMITATION, DAMAGES FOR LOSS OF PROFITS, BUSINESS INTERRUPTION, OR LOSS OF INFORMATION) ARISING OUT OF THE USE OR INABILITY TO USE THIS DOCUMENT, EVEN IF ATMEL HAS BEEN ADVISED OF THE POSSIBILITY OF SUCH DAMAGES.** Atmel makes no representations or warranties with respect to the accuracy or completeness of the contents of this document and reserves the right to make changes to specifications and product descriptions at any time without notice. Atmel does not make any commitment to update the information contained herein. Unless specifically provided otherwise, Atmel products are not suitable for, and shall not be used in, automotive applications. Atmel's products are not intended, authorized, or warranted for use as components in applications intended to support or sustain life.

© Atmel Corporation 2005. **All rights reserved.** Atmel®, logo and combinations thereof, Everywhere You Are®, AViVA®, and others are registered trademarks or trademarks of Atmel Corporation or its subsidiaries. Other terms and product names may be trademarks of others.



Printed on recycled paper.

5330C-IMAGE-07/05