

The FT-2106x-PCI boards are members of Alacron's family of high performance computing subsystems based on Analog Devices' ADSP-2106x SHARC (Super Harvard Architecture Computer) processor. The FT-2106x-PCI incorporates an array of up to eight SHARC processors and a unique architecture resulting in a low power, low cost, high performance compute accelerator. GFLOP performance is now available on a single board.

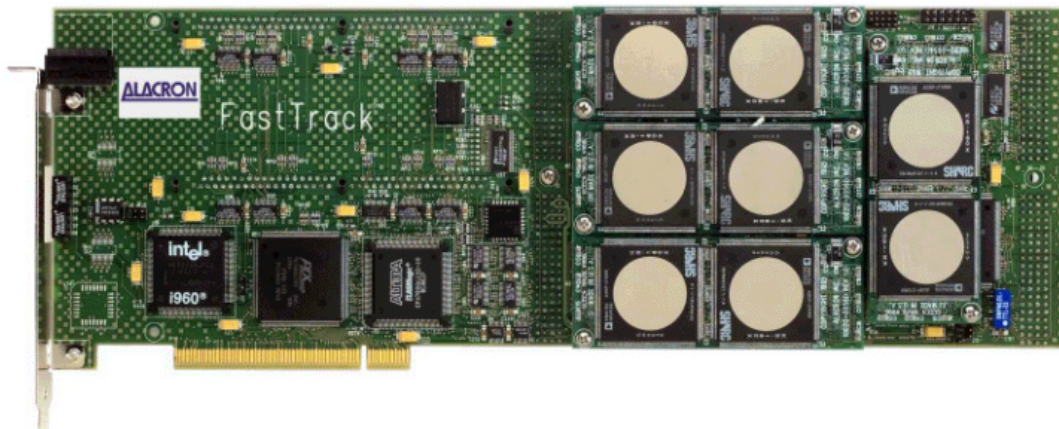

Alacron's FT-2106x-PCI delivers high levels of performance for imaging, graphics, simulation, DSP, document processing and pattern recognition applications. The FT-2106x-PCI is ideal for adding scalable compute capability to existing systems, or for developing new systems from the ground up.

Features

- 1, 2, 4, or 8 SHARC processor array
- Intel i960 control processor
- 960 MFLOPS peak performance
- 640 MFLOPS sustained
- 160 MB/sec peak local memory I/O
- Dedicated dual ported RAM
- Up to 128 MB global RAM
- FastTrack® connection to I/O and processor daughter-cards
- PCI master/slave/DMA interface, 132 MB/sec (peak)

ADSP-2106x SHARC Processor Array

The FT-2106x employs a buffered DMA local memory architecture which allows up to 8 processors in the SHARC array to run at "full throttle." Each SHARC processor has 1 MB of private dual-ported DRAM, and the SHARC array is isolated from the system bus by a 160 MB/sec DMA engine. The SHARC array is thus shielded from the impact of bus traffic and data movement. A separate Intel i960 control processor provides operating system functions, services interrupts, and controls bus traffic and data I/O, off-loading the SHARC array for data processing functions.

Alacron's FT-2106x-PCI computing subsystems use an innovative dual-ported memory interface between the control processor and a bank of Analog Devices ADSP-2106x processors to minimize the impact of data movement on processing by both the SHARCs and the host. In the SIMD mode, Alacron's application libraries distribute problems over several processors. All SHARC processors can access their private RAM banks at 80 MB/sec simultaneously. In MIMD processing mode, tasks are distributed to individual SHARC processors with Alacron's RT Operating Environment controlling multiple threads.

Performance

The FT-2106x series offers excellent performance of compute intensive algorithms. Representative performance measurement for specific SIMD algorithms from Alacron's libraries are shown.

Number of ADSP-2106x	1DCFFT (1K) (msec)	2DCFFT (1Kx1K) (msec)	CONV3 (512x512) (msec)	CONV5 (512x512) (msec)
1	0.457	1045	72	205
2	0.260	527	36	103
4	0.130	272	18	52
8	0.072	138	9	23.5
16	0.046	74	4.5	11.8

*16 SHARC performance is obtained by using one, eight-processor FT-2106x-PCI or FT-2106x-VME board -- along with one, eight-processor FT-2106x-DC daughter-card. Alacron's FT-2106x bus boards can support several FT-2106x-DC daughter-cards for multiple GFLOP-per-slot performance.

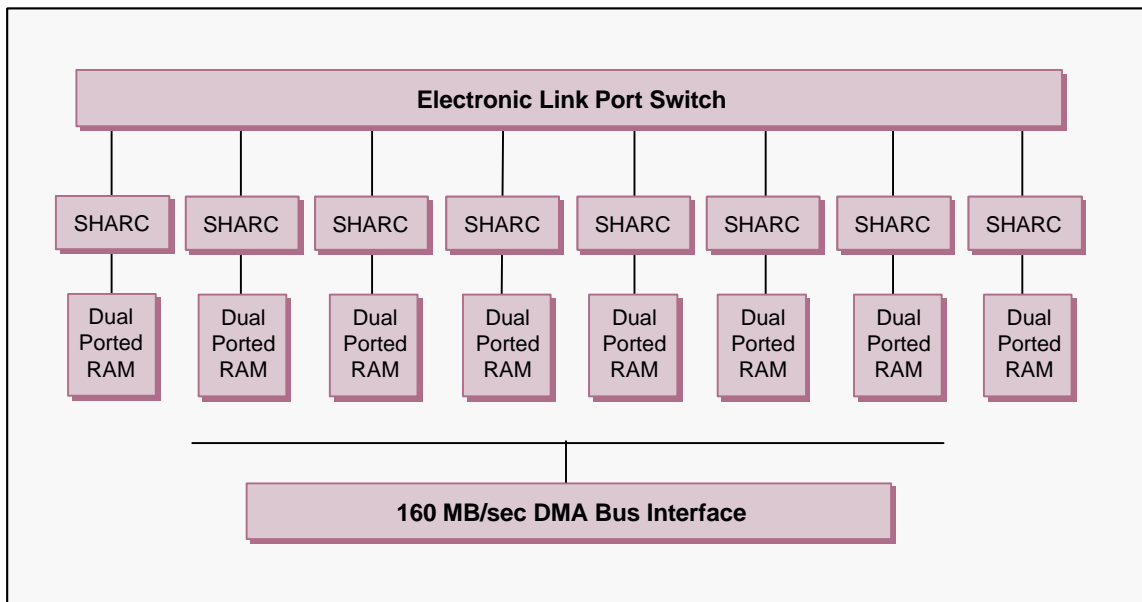

Specifications

Multiprocessors

Processor	Analog Devices ADSP-2106x
Number of	1, 2, 4, 8 ADSP-2106x
Clock Speed	40 MHz
Global DRAM	2 to 256 MBs
Dual Ported	1 MB/processor DRAM
External I/O	240 MB/sec peak 160 MB/sec sustained
Link Ports	Six per ADSP-21060/2
Link Port	(2) Software selectable
Topology	(4) Static
Data Bus	128 bit internal 32/48 bit external
Cache	32 x 48
DMA	10 channels 240 MB/sec External ports (4) Serial ports (4) Link ports (2, 4 shared)
Precision	IEEE floating point 32/40 bit precision
On Chip SRAM	4 Mbits ADSP-21060 2 Mbits ADSP-21062 1 Mbits ADSP-21061

Each ADSP-2106x SHARC processor provides:

- 40 MIPS
- 120 MFLOPS (A+B, A-B)
- 48/32 bit data bus
- 1, 2, or 4 MBit on chip SRAM
- DMA controller
- 2 serial ports (40 Mbits/sec)
- 6 link ports (240 MB/sec)
- SIMD and MIMD operation
- Concurrent DMA and computation

PCI Interface

Bus Specification.....32-bit PCI format
 Control Registers.....I/O mapped
 Global Memory.....Memory mapped

Daughter Card Interface

Interface.....FastTrack bus

Electrical and Environmental

Power.....+5 volts at 5A
 Dimensions.....107 mm x 312 mm x
 12.06 mm
 Operating Temp.....0-50 degrees centigrade
 Relative Humidity95% noncondensing

Software Support

Processing Environments

Alacron's RT operating environment provides several processing models. Applications can run as simple attached processes on the FT-2106x and as stand alone tasks on the host, or interactively, with separate tasks on the host and on the FT-2106x. Alacron's RT supports MS/ DOS, Windows 3.1, 95/98, NT, Solaris/Unix, LynxOS, and VxWorks.

Software Libraries

Alacron's FT-2106x computing subsystems are supported by an extensive suite of application specific libraries for image processing, DSP and graphics applications:

- Vector Numerical Library (VLIB)
- Real-time Image Processing Library (RIPL)
- Parallel Application Developer's Toolset (PARTOOL/PARLIB)

Development Tools

A full suite of ANSI development tools for the C language is available. Compilers support general purpose and numerically intensive applications. Both a JTAG and software GUI based debugger and profiler are available.